



MIRION
TECHNOLOGIES



**PASSIVATED IMPLANTED PLANAR SILICON (PIPS®)
DETECTORS FOR INDUSTRIAL APPLICATIONS AND
PHYSICS RESEARCH**

Silicon Detectors





Mirion Passivated, Implanted, Planar Silicon (PIPS) detectors have proven themselves in thousands of applications worldwide. Innovations driven by the myriad of applications we serve have resulted in continuous improvements to the performance of the PIPS technology. This technology drives our alpha spectroscopy, beta detection, continuous air monitors, and various nuclear physics and space experiments.

For over 30 years, our specialized team has designed, developed, manufactured, tested and shipped the highest quality PIPS detectors to our customers around the world.

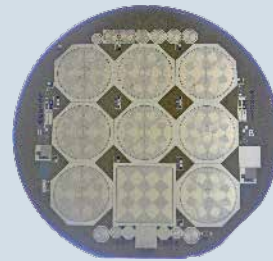
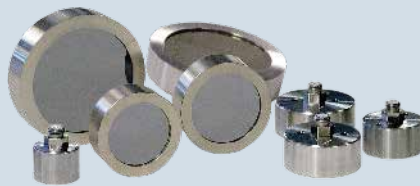

MIRION
TECHNOLOGIES

Charged Particle Detection

(E-Detectors)

Nuclear Physics, Astrophysics and Radiation Protection

EXCELLENT RESOLUTION FOR ALPHAS, BETAS, PROTONS, ELECTRONS, HEAVY IONS AND MORE

- Entrance window < 50 nm on all models
- Low Energy Betas and Electrons

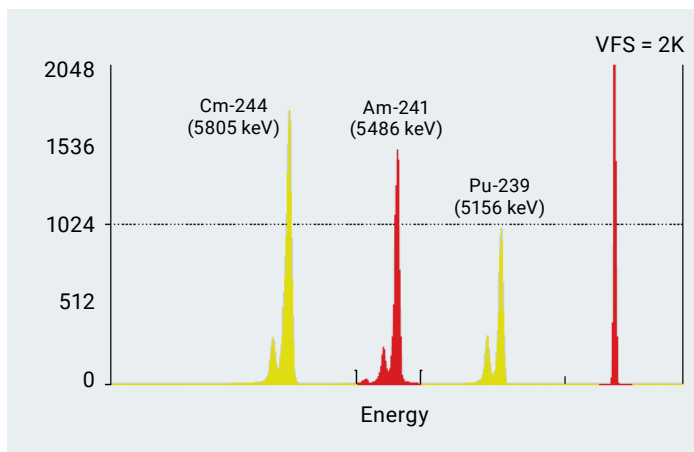
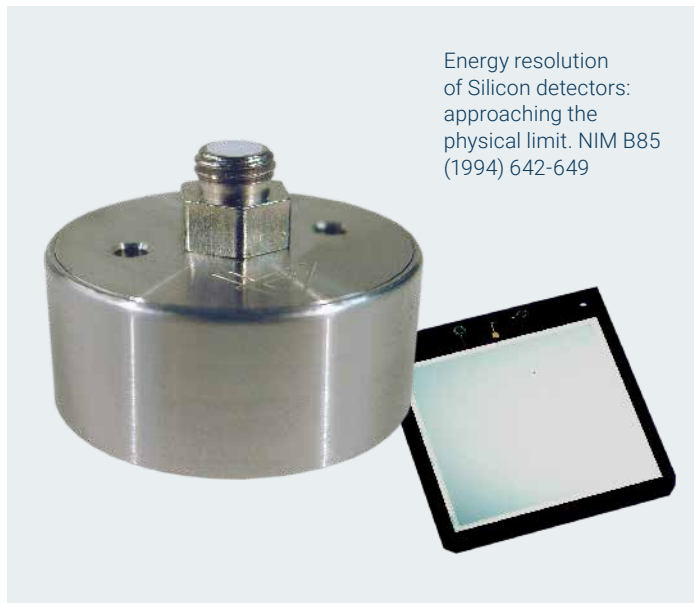

Square and Rectangular Detectors: RF Series

DIMENSIONS: ACTIVE AREA

- 10 x 10 mm – 14 x 14 mm – 30 x 30 mm – 50 x 50 mm – or other on request

FEATURES

- Thin junction window: ≤ 50 nm
- Ohmic window ≤ 1500 nm (for fully depleted series)
- Standard mounting on epoxy board (suffix EB)

OPTIONAL

- Ultra thin junction window ≤ 25 nm (prefix TW)
- Timing resolution: < 200 psec (FWHM)
- Thin ohmic window ≤ 150 nm (prefix TB)
- Mounted in a metal housing

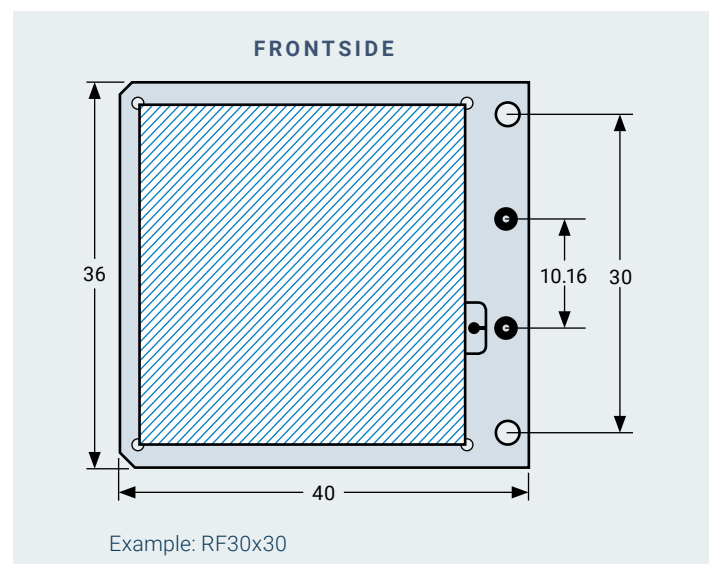

Charged Particle Detection

(E-Detectors)

Nuclear Physics, Astrophysics and Radiation Protection

Radiochemistry and Physics Research: PD, RF and A-Series

FEATURES

- Single junction in metal housing or on epoxy board
- Size: 25 to 5000 mm²
- Active thickness: 100 to 1000 μm thickness

ADVANTAGES

- Stability and reliability detectors available from stock
- Excellent resolution
- Low background
- High efficiency



Alpha Analyst™ Integrated Alpha Spectrometer

Continuous Air Monitoring – CAM-Series

FEATURES

- Ruggedized detector in metal housing
- Size: 300 to 5000 mm²
- Active Thickness: 100 to 500 μm

ADVANTAGES

- Excellent reliability
- Perfect alpha, beta separation
- Can replace gas detectors in alpha, beta counters
- Gamma guard versions available. Operation in combination with a plastic guard detector as in iSolo[®] system

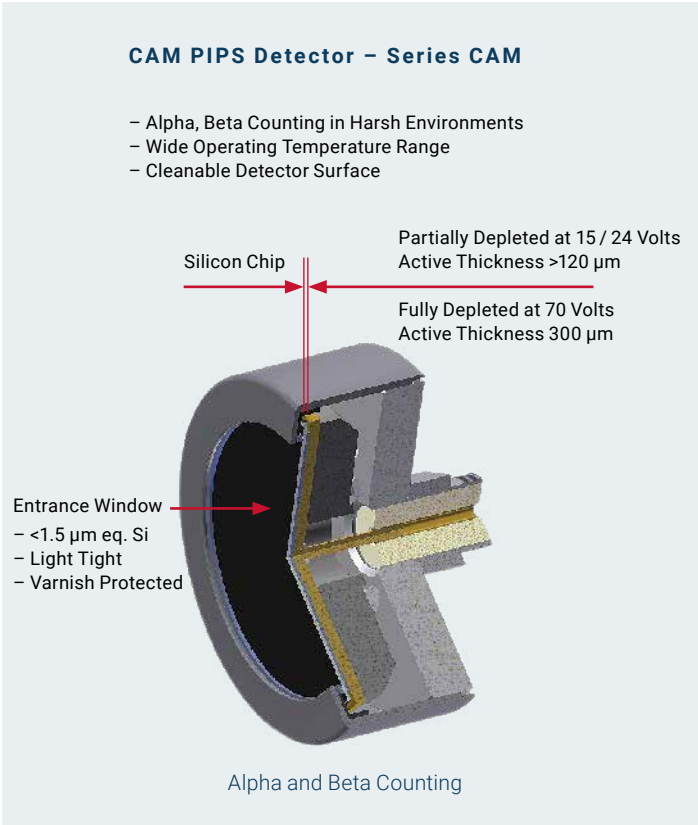
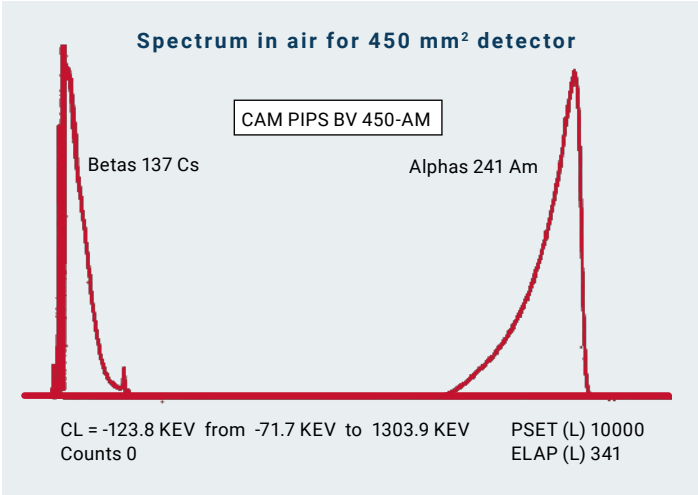

Charged Particle Detection

1D Position Sensitive Detectors

PF-CT-Series

FEATURES

- Pad detector mounted on epoxy boards
- Sizes available: see www.mirion.com or others on request
- Active thickness: 200 to 1000 μm

ADVANTAGES

- Excellent resolution
- Can be assembled on customer board
- Models available from stock

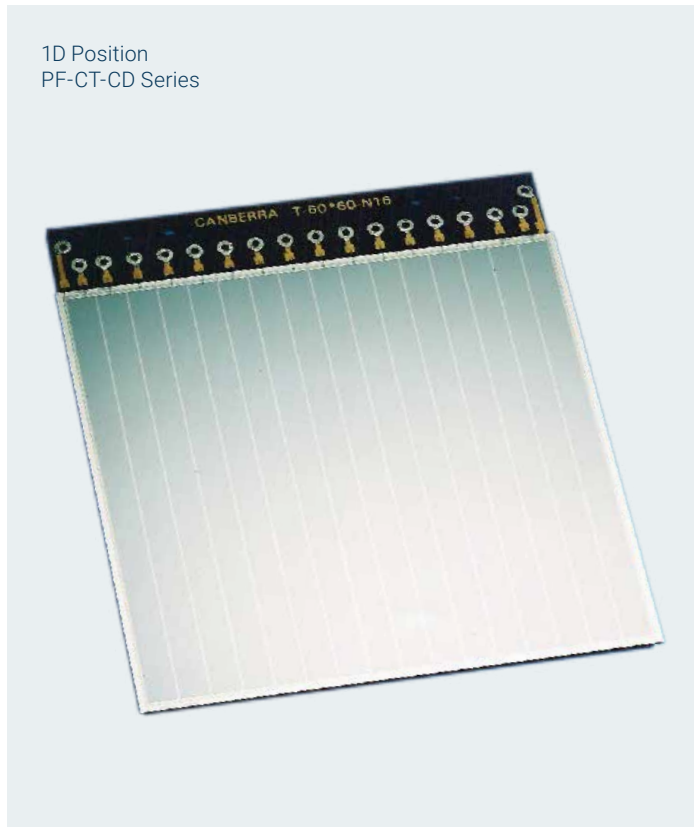

2D Position Sensitive Detectors

Pad Detectors – PF-RT Series

FEATURES

- Pad detectors mounted on epoxy boards
- Size: from 40 x 40 mm^2 on or others on request
- Active thickness: 300 and 500 μm

OPTIONAL

- Ultra thin junction window $\leq 25 \text{ nm}$ (prefix TW)
- Resistive Pads: PF-RT-Series
- Thin ohmic window possible $\leq 150 \text{ n}$

ADVANTAGES

- 2D Position information (for energies $>2 \text{ MeV}$)
- Modest requirement for read-out electronics
- Single sided process
- Can be assembled on customer board
- Models available from stock

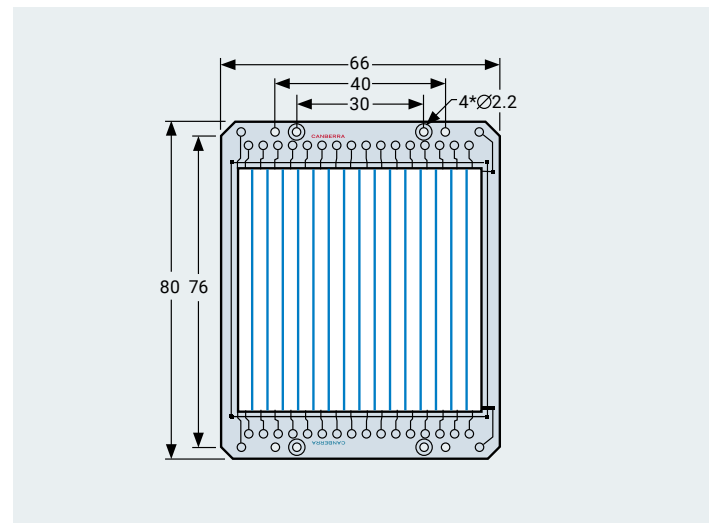

2D Position Sensitive Detectors

Double-Sided Strip Detectors: PF-CT-CD Series

FEATURES

- Strip detectors mounted on epoxy boards
- Size: from 40 x 60 mm² and larger or others on request
- Active thickness: 200 to 1000 μm

ADVANTAGES

- Good timing performance
- Can be assembled on customer board
- Models available from stock

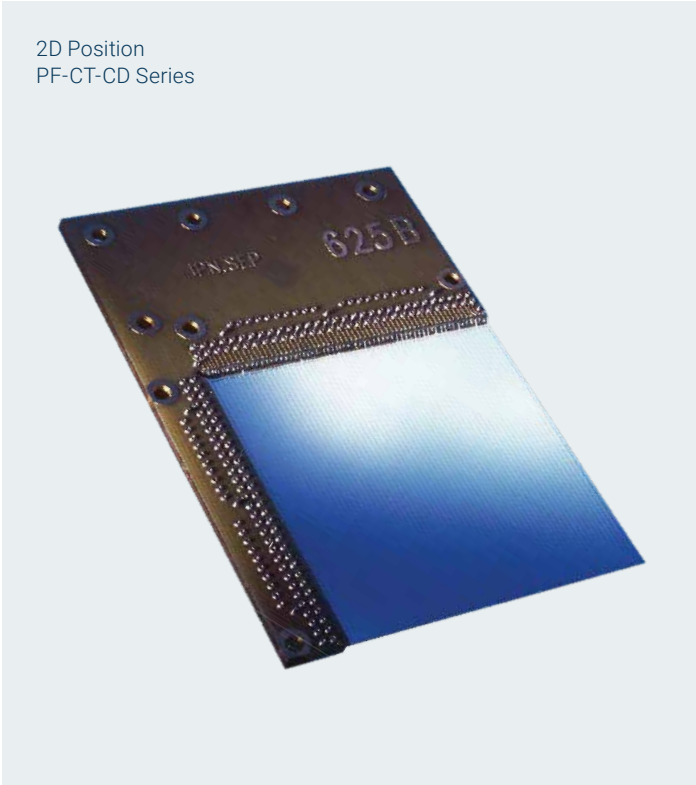

2D Position Sensitive Detectors

Segmented Pixel Detectors: CD Series

FEATURES

- Pixel detectors mounted on epoxy boards
- Size: custom design
- Active thickness: 200 to 1000 μm

ADVANTAGES

- Good resolution (low capacitance)
- Can be assembled on customer board

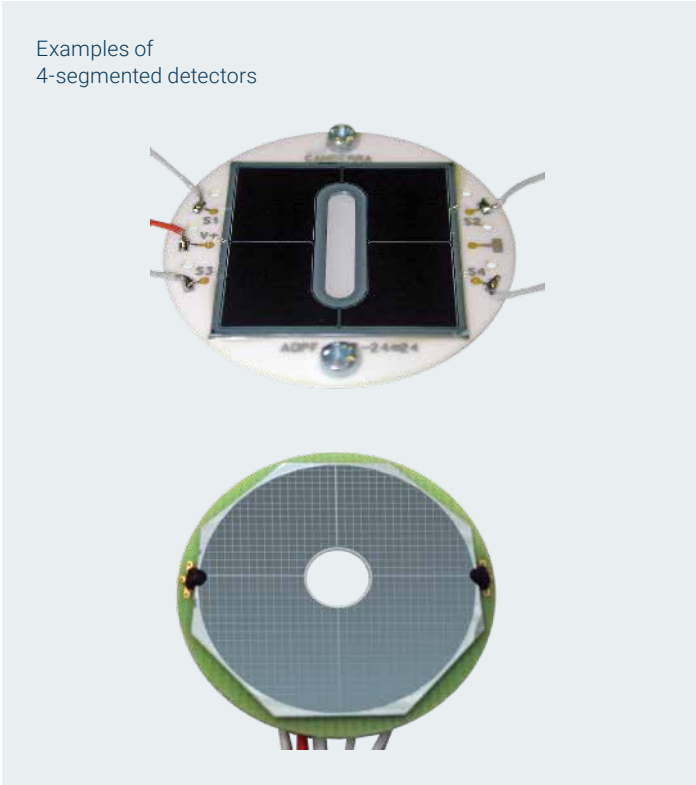

Particle Identification

(ΔE -Detectors)

Nuclear Physics, Astrophysics and High Energy Physics

Fully Depleted Detectors: FD-Series Series

FEATURES

- Single junction in metal housing
- Size: 25 to 900 mm²
- Thickness: 200 to 1000 μm

ADVANTAGES

- Excellent resolution
- Thin windows
 - Entrance window < 50 nm
 - Exit window < 150 nm up to 500 μm thickness
- Detectors available from stock
- Telescope assemblies

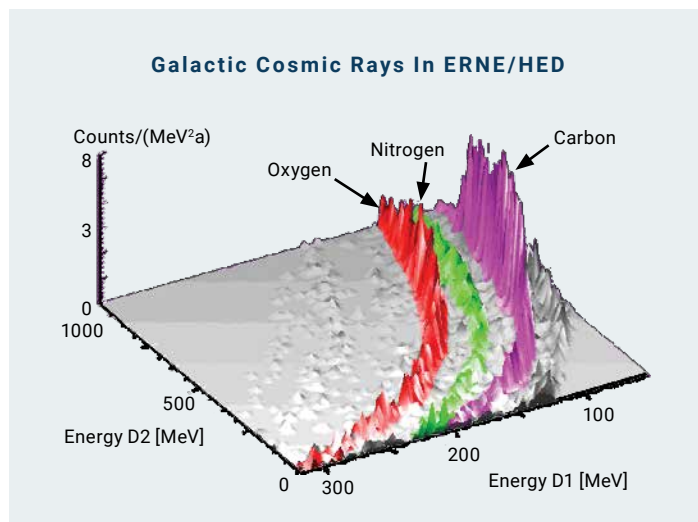

MOUNTS AND DIMENSIONS

- See chart and drawings
- Detector face is recessed 1.0 mm in AM, AB, RM, ABM and SMC mounts

Detector Size (mm ²)	Active Diameter (mm)	Axial X (mm)	Radial X (mm)
25	5.7	16.7	19.4
50	8.0	16.7	19.4
150	13.8	23.6	26.1
200	16.0	28.6	31.6
300	19.5	28.6	31.6
450	23.9	32.0	34.8
490	25.0	33.4	N.A.
600	27.6	36.1	38.4
900	33.9	45.2	50.0
1200	39.1	48.8	53.0
1700	46.5	59.0	N.A.
2000	50.0	65.5	70.0
3000	61.8	76.2	80.0
5000	79.8	94.0	N.A.

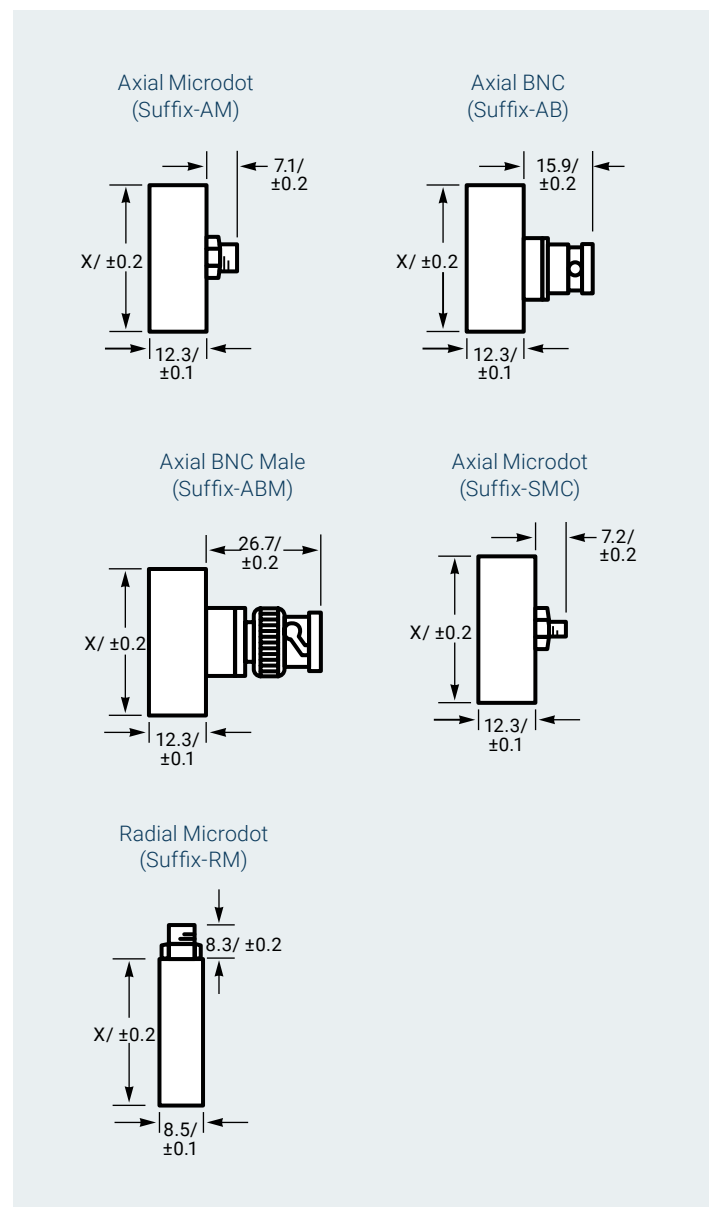

Special Applications

Photodiodes for Synchrotron Applications

FEATURES

- Single or multiple junction on ceramic board
- Size: 50 to 550 mm²
- Active thickness: 200 to 1500 μm

ADVANTAGES

- Low dark current, typically below 1 nA/cm²
- Fast read-out
- Used in photovoltaic or biased mode
- No optical window

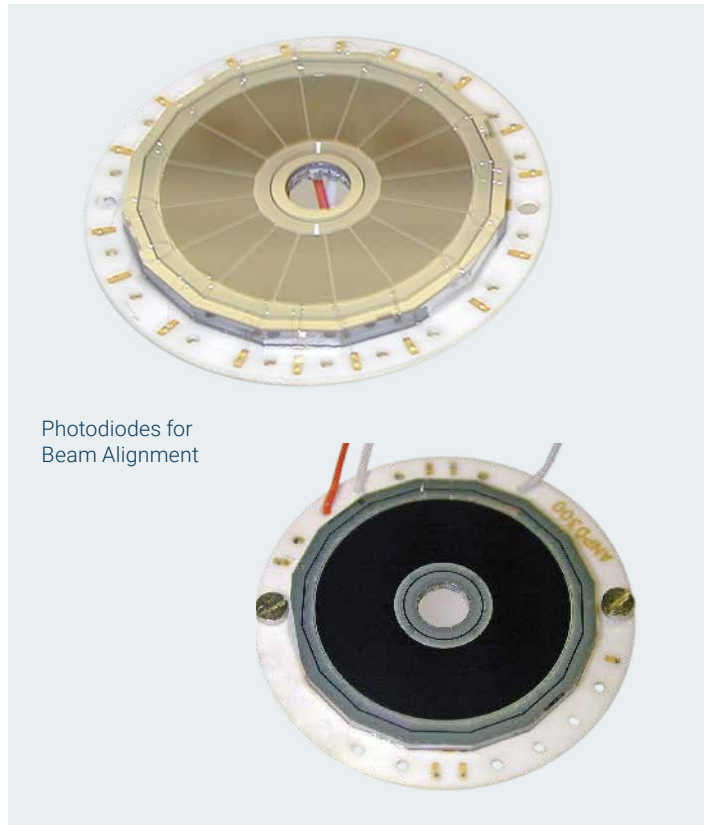

Customized Detectors for Space

PIPS Detectors for Space Exploration

FEATURES

- Thickness: 200 to 500 μm
- Anti-reflective coating with QE > 80%
- Low dark current and direct coupling to scintillator
- Extremely rugged and low power requirement
- Awarded by NASA for the contribution to the Mars ROVER MSL Rad project
- PIPS detectors are deployed on the following current or recent missions:
 - STEREO and DOUBLE STAR studying solar storms, MESSENGER and BEPICOLOMBO study Mercury, CHANG'E-4 to study the moon, SOLAR ORBITER to study the heliosphere of the sun, NEW HORIZONS passed Pluto to outer space in a second extended mission.

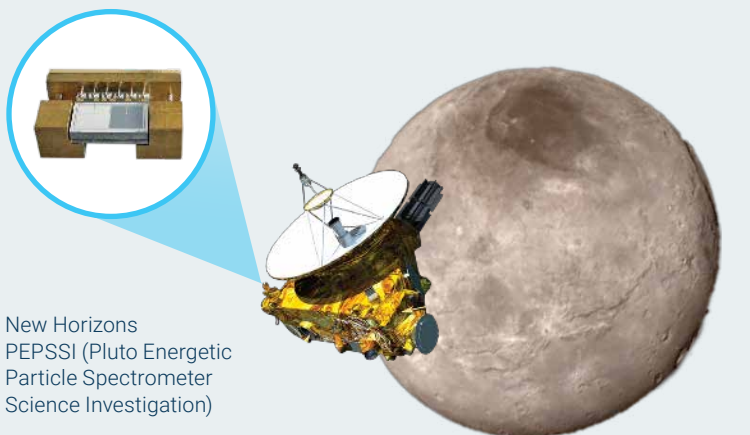

New Horizons
PEPSSI (Pluto Energetic
Particle Spectrometer
Science Investigation)

The New Horizons spacecraft carries the PEPSSI instrument, a spectrometer designed to detect electrons and ions in the 30 keV – 1 MeV energy range. One of the aims of the PEPSSI team (located at the Johns Hopkins University Applied Physics Laboratory) is to study the interaction between the Pluto system and the solar wind by detecting neutral particles from Pluto's atmosphere that are ionized by the Sun's light and then picked up and accelerated by the electromagnetic field of the ~1.5 million km/hour solar wind.

Cassini

Mirion Technologies supplied the custom design PIPS detectors integrated in the MIMI LEMMS and CHEMS sensors. They detected energetic charged particles (protons, electrons, ions) in the excited gas, or plasma, around Saturn.

- The Low-Energy Magnetospheric Measurement System, known as LEMMS, measured the number of electrons, protons and ions that struck its detectors, as well as how fast they were traveling and what directions they were coming from.
- The Charge-Energy-Mass Spectrometer, called CHEMS, measured the charge and composition of the particles that struck its detectors. Each particle's mass tells scientists what element it is, for example, whether it's a proton or a "water group" ion such as H₂O⁺.

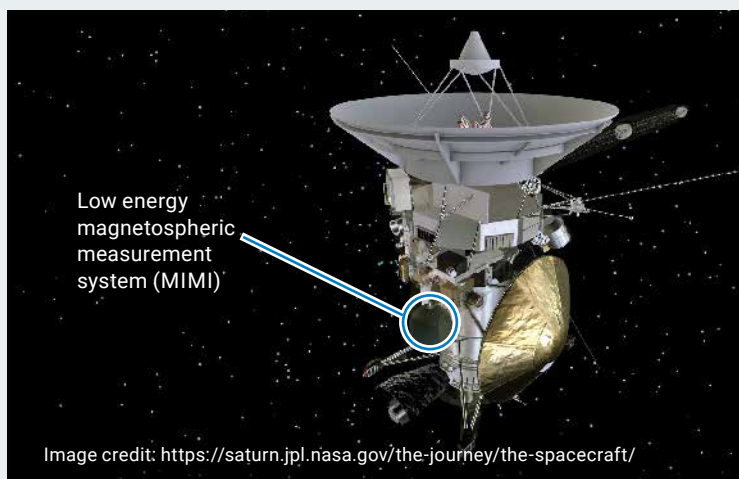

Image credit: <https://saturn.jpl.nasa.gov/the-journey/the-spacecraft/>

Launched on Oct. 15, 1997, Cassini's mission to explore Saturn ended on Sept. 15, 2017 with a deliberate plunge into Saturn's atmosphere.

Customed Detectors for Space

Photodiodes for Scintillator Read-Out

EXAMPLE: Advanced Photon Detection on the MARS ROVER

FEATURES

- Size: Custom Design
- Thickness: 200 to 500 μm

ADVANTAGES

- Anti-reflective coating with QE > 80%
- Low dark current
- Direct coupling to scintillator
- Optimization for specific scintillators

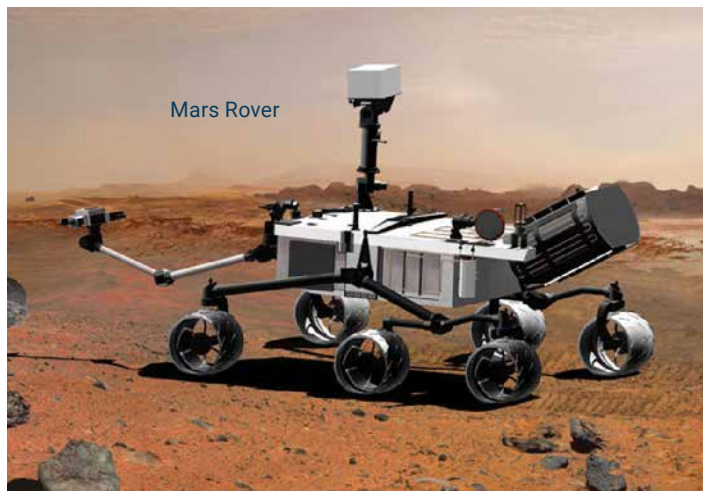
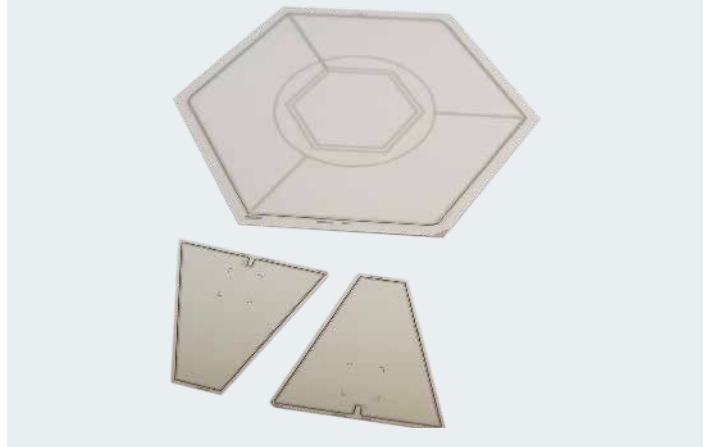
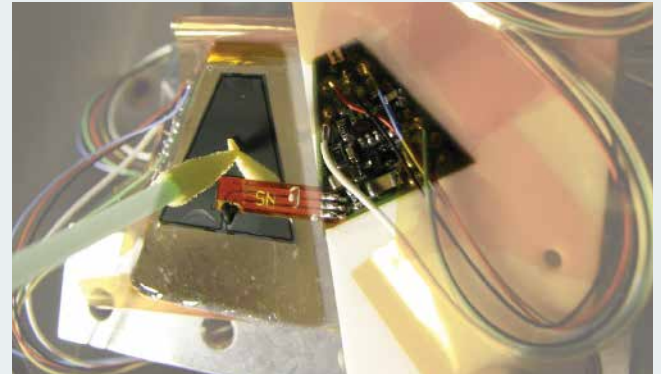

OEM Solutions

XRF-XRD-EDS Benchtop and Handheld Systems

The Mirion SDD product range is targeted to be integrated in handheld and benchtop XRF systems.

Mirion develops designs, manufactures and assembles everything in-house, which has made us the partner of choice for a good number of industrial partners.

OEM solutions for XRF-XRD-EDS Benchtop and Handheld

FEATURES

- Silicon Drift Detector (SDD) product range is targeted for integration in handheld and benchtop XRF systems
- Includes compact preamplifier
- All products are developed, designed, manufactured and assembled in house to customer specifications
- JFET or CMOS based front stage amplification

AVAILABLE AS

- TO8 module
- Including compact preamplifier
- JFET or CMOS based front stage amplification
- Custom made designs possible

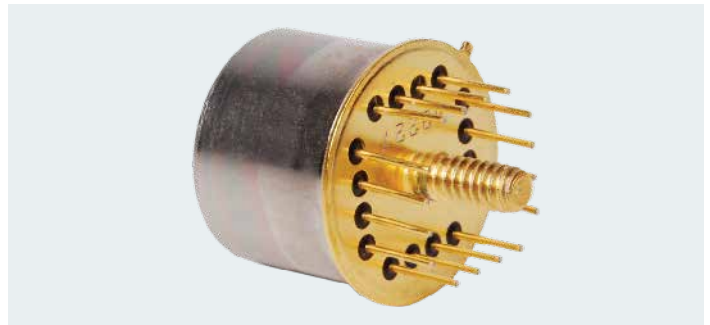
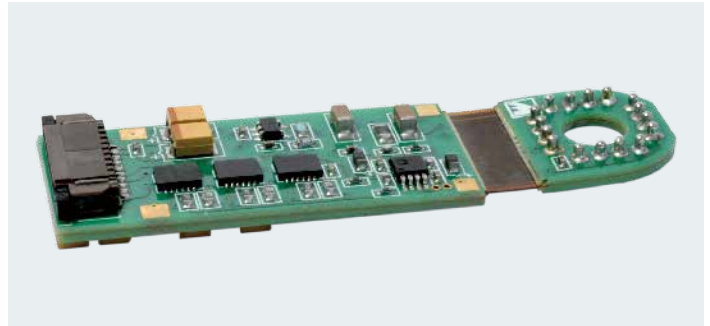

Mirion Missions in the Milky Way

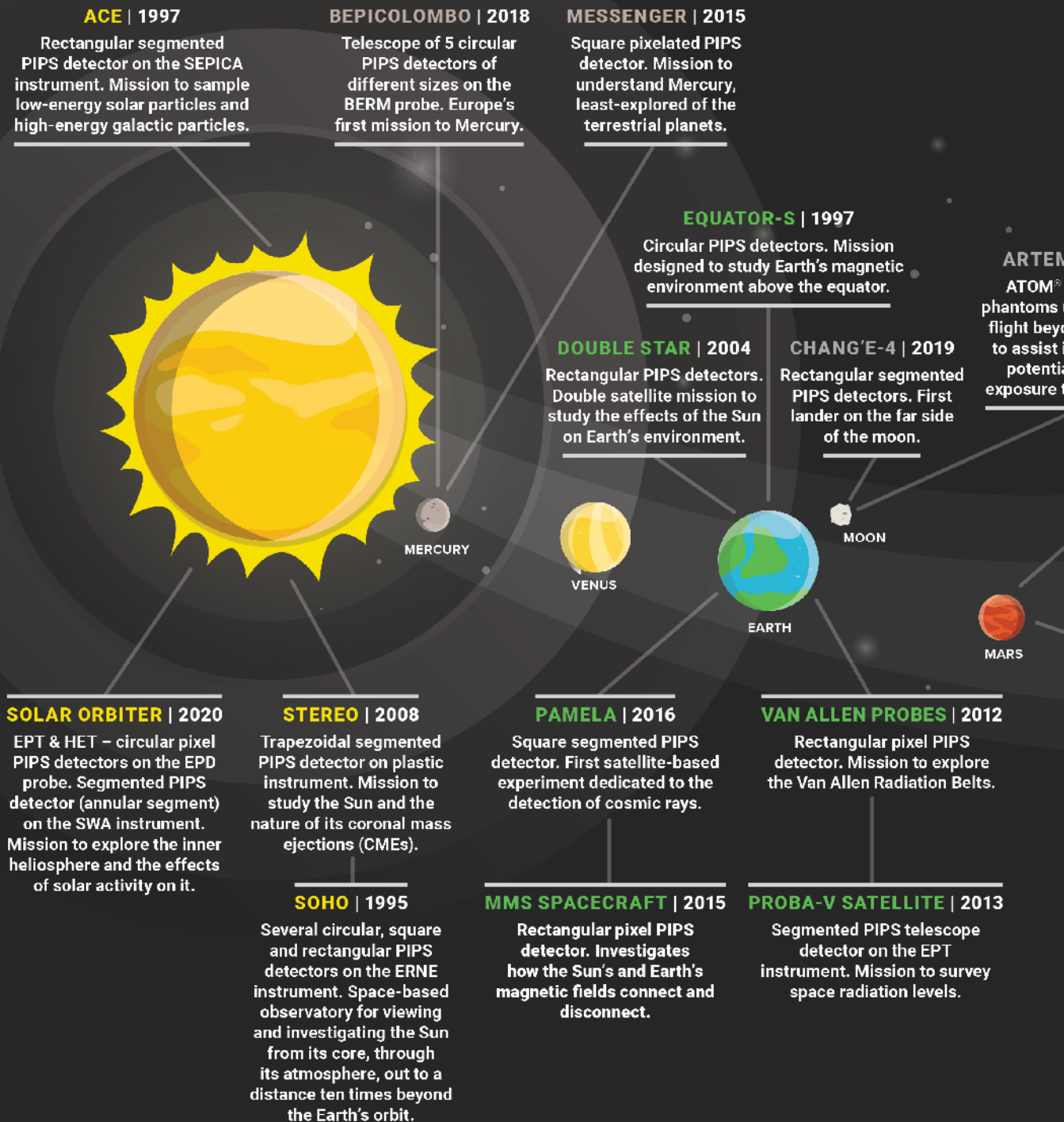

PIPS detectors are deployed on the following current or recent missions; STEREO and DOUBLE STAR studying solar storms, MESSENGER and BEPICOLOMBO study Mercury, CHANG'E-4 to study the moon, SOLAR ORBITER to study the heliosphere of the sun, NEW HORIZONS passed Pluto to outer space in a second extended mission.

CUSTOMER TESTIMONY:

“ I was extremely happy working with this team. In our initial design we frequently met by phone and worked through different options. They provided excellent suggestions, and together we came up with the best solution. They were available to meet with very little notice, had excellent technical expertise, and kept the effort moving on or ahead of schedule. ”

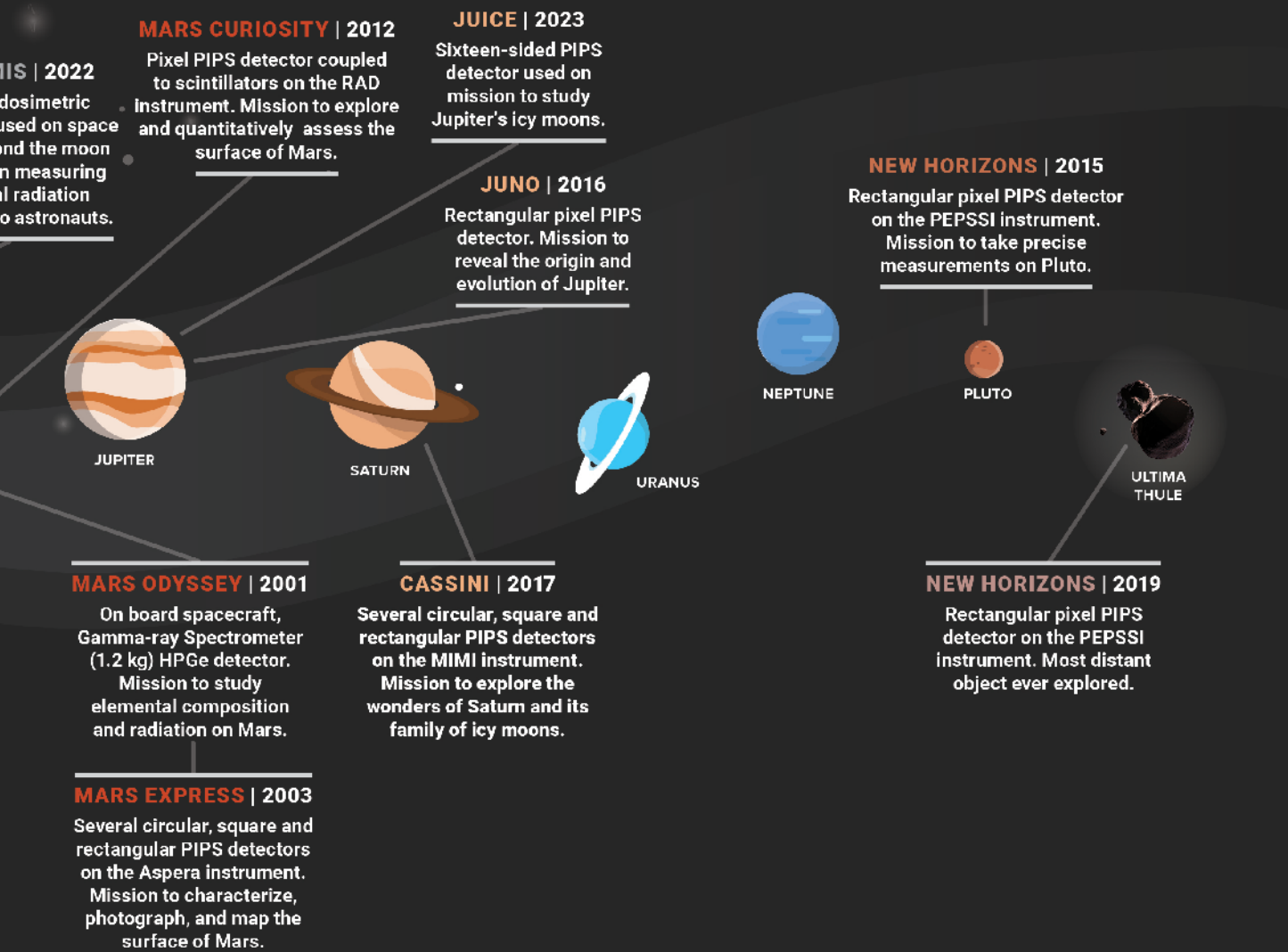

Photon Detection

(From Near UV to 30 keV)

X-ray Spectroscopy, X-ray Diffraction and Synchrotron Applications

X-PIPS™ Series (Based on Drift Technology)

FEATURES

- Preamplifier included
- Temperature-controlled Peltier cooler included
- Size: 15 mm² and 30 mm²
- Thickness: 500 μm

ADVANTAGES

- Excellent resolution < 132 eV
- Peak/Background > 15000
- Good stability
- Good performance with fast shaping time (< 1 μs rise time)

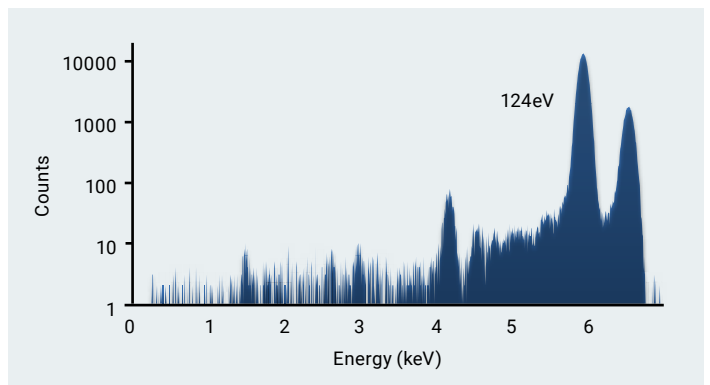
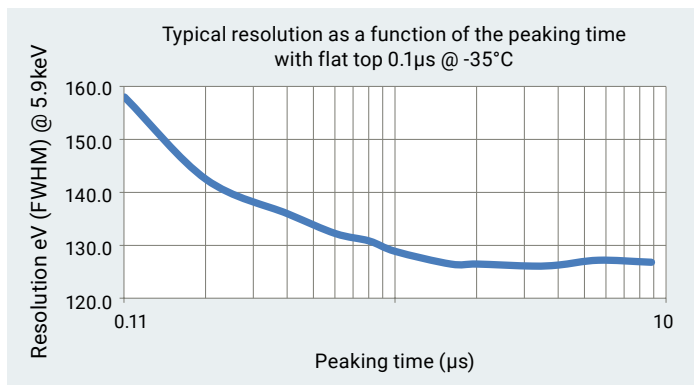

High Count Rate 7-Element Detector

FEATURES

- Array of 7 individual SDD's of 100 or 70 mm² (collimated to 80 or 50 mm²) and 500 μm thickness in a close-packed geometry
- CMOS preamplifier (CUBE based)
- 1 mil Be window
- Detector system includes preamplifiers, HV power supply and temperature controller
- Cryo-cooled electrical cooling

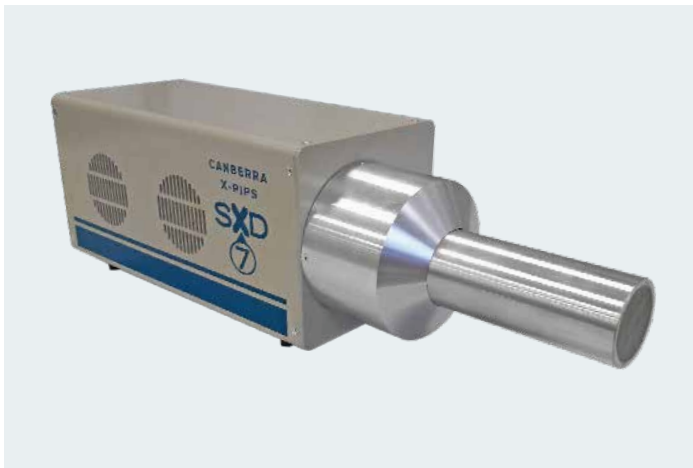

Custom Multi-Element

FEATURES

- Up to 13 or more elements
- Planar or focused configurations
- Easily customizable





Mirion Technologies provides products and services for a wide range of radiation safety, measurement and scientific purposes.

Mirion solutions are employed to protect people from radiation exposure and limit the spread of contamination. Since 1968, the company has also been committed to the development, manufacturing and service of unique specialty detectors for international scientific experiments, as well as industrial applications.

Driven by the diverse needs of our customers, Mirion has developed a range of solutions to maintain its technological leadership in the nuclear measurements industry.

Mirion supplies detectors and instrumentation used in laboratory and in-situ radiological analysis, and for cutting-edge materials analysis, physics, and space studies in some of the world's leading research institutes.

Our dedicated R&D structure allows us to deliver innovative nuclear detection systems based on a comprehensive exploration of all available and emerging technologies.

Our passion for fully understanding the needs of our customers is key to our ability to provide the best solutions to contribute to their success.

Mirion Services augments your technical team, assists during peak periods, provides expert advice, trains staff and maintains your systems for optimal performance. We look forward to partnering with you.



Mirion Technologies (Canberra Olen) NV, Lammerdries-Oost 25, B-2250 Olen Belgium

Empowering Progress Across Continents

Mirion Technologies combines innovative radiation safety technologies with unrivaled expertise, cultivated over decades of collaboration with reactor manufacturers and operators, nuclear fuel facilities, regulators, national labs (such as the U.S. DOE), nuclear institutes, universities, and national military/security organizations worldwide.

Trust us to provide the solutions and support you need to safeguard your valuable assets and ensure a secure and sustainable future.

 CORPORATE HQ (ATLANTA, GA)  MANUFACTURING SITES  SERVICE & SALES CENTERS



2,700 PEOPLE IN 12 COUNTRIES



Protect What's Next™



MIRION
TECHNOLOGIES

Copyright © 2023 Mirion Technologies, Inc. or its affiliates. All rights reserved. Mirion, the Mirion logo, and other trade names of Mirion products listed herein are registered trademarks or trademarks of Mirion Technologies, Inc. or its affiliates in the United States and other countries. Third party trademarks mentioned are the property of their respective owners.