



RMS 250

RMS 250™

Radiation Monitoring System

High qualified solutions for nuclear applications.



FEATURES

- Calibrated monitors for radiation protection and process monitoring assembled with qualified components: detectors, measuring vessels, lead shieldings; cables, signal processing, test equipment

DESCRIPTION

The monitors of the system RMS 250 are designed for fixed installed, safety related measuring channels classified by the German nuclear regulations KTA1501 ff and KTA3501 or similar international regulations.

- Dose rate monitoring according to KTA1501 and KTA1506
- Monitoring of radioactive aerosols, iodine and noble gases according to KTA1502 and KTA1503.1
- Stack monitoring for post accident conditions according to KTA1503.2
- Liquid monitoring according to KTA1504
- Dose rate and activity monitoring for research reactors according to KTA1507
- N-16 monitoring for detection of steam generator leakages according to KTA3501

Dose Rate Monitoring, Area Monitoring according to KTA 1501 and KTA 1506							
Meas. Range (Sv/h)	Detector	Detector Temperature		Check Source	Detector Cable	Signal Processing	Signal Paths
		Continuous	1h max.				
1e-3 ... 1e+5 1e-5 ... 1e+5	KG 50 SEC KG 80 PEF	0 ... 135°C -25 ... 100°C	205°C / 3h 120°C	ch. vol.	2 x cer. coax 4 x coaxial	NV102 + DPK251-K2xxx NV102P + DPK251-K2xxx	1 ... 4 1 ... 4
1e-7 ... 1 1e-6 ... 1	KG 122 SBL KG 122 PEF	0 ... 80°C 0 ... 100°C	120°C	TKA 17 ch. vol.	2 x coaxial 4 x coaxial	NV102 + DPK 251-K2xxx NV102P + DPK251-K2xxx	1 ... 4 1 ... 4
1e-7 ... 100 1e-7 ... 100	KG 151 REZ KG 220 SEU	-25 ... 150°C -30 ... 120°C	180°C 165°C	TKA 15 TKA 16	2 x coaxial 2 x coaxial	NV102 + DPK 251-K2xxx NV102 + DPK251-K2xxx	1 ... 4 1 ... 4
1e-7 ... 0.3 1e-7 ... 1e-2	KG 220 EEM ZG 50 A1	0 ... 80°C -25 ... 70°C		TKA 16 TKA 52	2 x twist.pair 2 x twist.pair	DPK 251 K12xx/14xx DPK 251 K12xx/14xx	1 ... 4 1 ... 4

Monitoring of Radioactive Noble Gas according to KTA 1502 and KTA 1503.1							
Meas. Range for Xe-133 (Bq/m ³)	Detector	Measuring Vessel	Lead Shielding	Check Source	Detector Cable	Signal Processing	Signal Paths
2e+3 ... 1e+9 1e+4 ... 1e+10	SB 150 SB 40	RSD 275 RSD 200	RSA 481/482 RSA 310/311	TKA 61 TKA 61	TKK 05 TKK 05	DPK 251-K52xx/54xx DPK 251-K52xx/54xx	1 ... 4 1 ... 4

Liquid Monitoring according to KTA 1504							
Meas. Range for Cs-137 (Bq/m ³)	Detector	Meas. Vessel or Principle	Lead Shielding	Check Source	Detector Cable	Signal Processing	Signal Paths
3e+3 ... 3e+8 5e+3 ... 1e+9 typ. 1e+4 ... 1e+10	SG 65 M SG 65 M SG 65 M	RSD 135 RSD 221 Off line	- RSA 428 Proj. spec.	TKA 54 TKA 54 TKA 54	TKK 05 TKK 05 TKA 05	DPK 251-K52xx/54xx DEK 251 / DPK 251 DPK 251-K52xx/54xx	1 ... 4 1 ... 4 1 ... 4

Monitoring of Radioactive Aerosols and Iodine according to KTA 1502 and KTA 1503.1							
Detected Activity	Measuring Range (Bq/m ³)	Monitor and Detector		Check Source	Detector Cable	Signal Processing	Signal Paths
Beta aerosols Gamma aerosols Iodine	2 ... 1e+5 for Cs-137 1 ... 1e+4 for Cs-137 1 ... 1e+4 for I-131	AD 24 AG 24 JD 24	SB 40 SG 65 M SG 65 M	TKA 47 TKA 47 TKA 10	TKK 05 TKK 05 TKA 05	DPK 251-K10x DPK 251-K30x DPK 251-K40x	1 1 1

Monitoring of Steam Generator Leakages according to KTA 3501							
Detected Activity	Measuring Range (Bq/m ³)	Monitor and Detector		Check Source	Detector Cable	Signal Processing	Signal Paths
N-16	Main steam line	1 ... 1e+5	SG 66	TKA 54	TKK 05	DAK 250-i	1

Stack Monitoring for Post Accident Conditions according to KTA 1503.2							
Detected Activity	Measuring Range (Bq/m ³)	Monitor	Detector	Check Source	Detector Cable	Signal Processing	Signal Paths
Aerosols Iodine-131	100 ... 2e+8 (1e+11) 20 ... 2e+7 (8e+11)	FA/J 51 SG	SG 65 M	TKA 63	TKK 05	DEK 251.K20x	3
Xenon-133	1e+8 ... 1.5e+14 8e+5 ... 3.7e+15	RSD 211 (NGM 203)	KB 100 CHMC 01	TKA 61 TKA 70	TKK 12	NV102 + DPK251 NV103 + DPK251	1 ... 4 1 ... 4

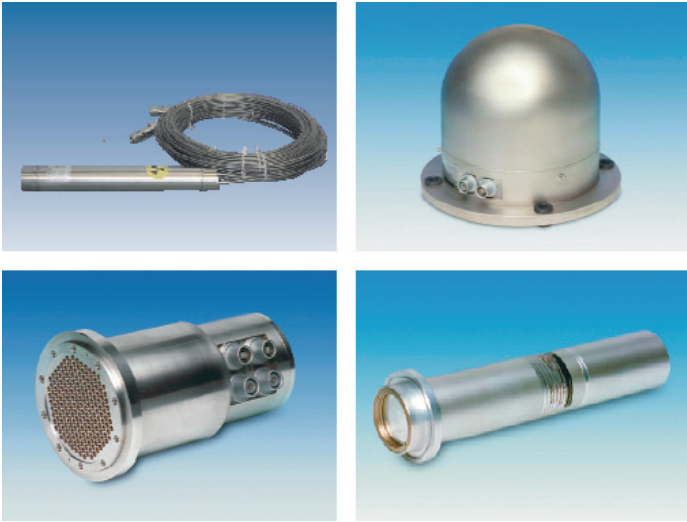

DETECTORS

A variety of type tested detectors is available to transform the physical quantity “nuclear radiation” (e.g. particle flux or dose rate) into a electrical signal:

- Gamma ionization chambers for dose rate monitoring
- Beta ionization chambers for noble gas monitoring
- Gamma and beta scintillation detectors for activity monitoring
- Large-area silicon detectors for alpha and beta monitoring
- GM-detectors for simple applications
- BF3 proportional counter tubes for sensitive neutron monitoring

DIGITAL SIGNAL PROCESSING CHANNELS

Digital electronic channel systems TK 250 are designed for signal processing of dose rate and activity monitors. They are characterized by efficient functions, a comfortable operators menu structure and a reliable and rugged operational behaviour. Hardware and software are organized in modules. This results in a high flexibility to adapt to different applications and customer needs.

Interfacing of pulse detectors and ionization chambers is achieved by different preamplifiers or input boards. Remote operated test generators on the input boards and signal simulation at different points of the digital processing sequence allow efficient procedures for periodical testing.

Hardware and software of the system are type tested according to KTA1505 and KTA3505, therefore it may be used for functions of category A and B of IEC61226.

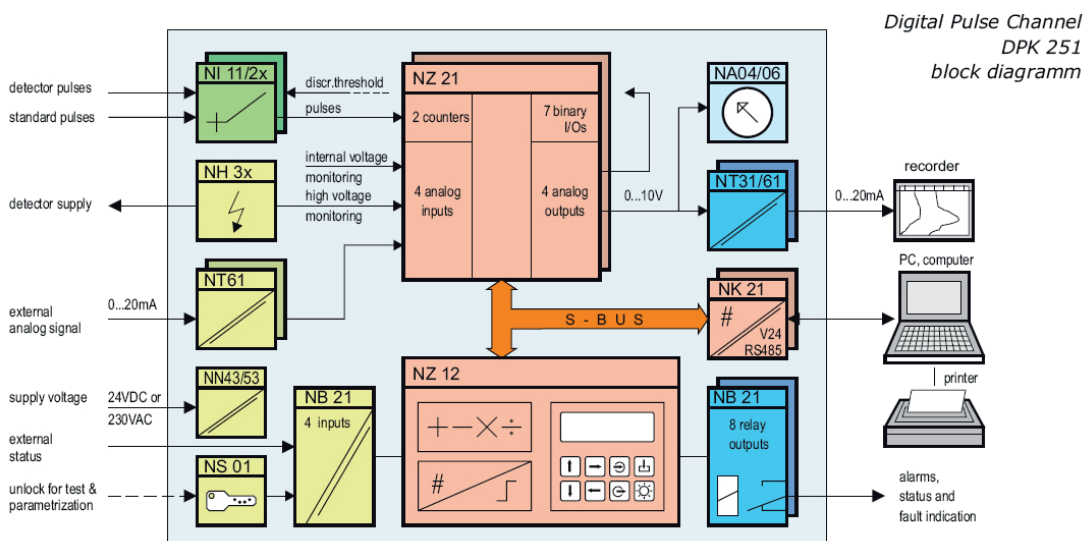

SIGNAL PROCESSING CHANNELS (For different applications)

- **DPK 251** Digital Pulse Channel for dose rate and activity monitoring with 2 or 4 signal paths
- **DFK 251** Digital Filter Channel for particulate and iodine monitors
- **DEK 251** Digital Effluent Monitoring Channel e.g. for post accident monitors
- **DAK 250** Digital Start-up Channel for applications in category A

INPUT SIGNALS

- Detector pulses: > 30 ns up to 5e6 cps
- 5V standard pulses: >1 μs up to 4e5 cps
- DC currents: from 0.1 pA to 1 mA
- Analog signals: 0/4 ... 20 mA
- Binary signals:
- 24V-logic, contacts, NAMUR-Sensors
- Detector supply:
- 0 ... 1 kV, 2 mA or 0 ... 2 kV, 1 mA or 0 ... 4 kV, 0.5 mA

POWER SUPPLY

- 18 ... 33 VDC, approx. 1.6A at 24 VDC or
- 230 VAC or 115 VAC +10%/-15%; 48...62 Hz, approx. 40 VA

OUTPUT SIGNALS

- Linear or logarithmic analog outputs:
- Measuring range to be adjusted with parameters
 - 0 ... 10 V internal, optional analog indicator
 - 0 or 4 ... 20 mA, 0 ... 600 Ω load, floating
- Up to 20 different alarms, adjusted by parameters:
 - Low or high alarm to be selected for all variables
 - Threshold and hysteresis adjustable
- Binary outputs, e.g. for alarms, status signals relay change overs, 60V/0.5A or 125V/1A

ENVIRONMENTAL CONDITIONS

- Ambient temperature (modules): 0 ... 70°C (32 ... 158°F)
- Storage temperature: -30 ... 85°C (-22 ... 185°F)
- Humidity: < 95%
- Seismic conditions: ≤5 g, 5 ... 100 Hz
- Mechanical stress: ≤30 g, 11 ms

MECHANICAL CONSTRUCTION

- 19" modular system according to IEC 60297
- Printed board size: 100 mm × 160 mm (3.9 in × 6.3 in)
- Front panels: 20 mm × 128 mm (0.8 in × 5 in) or multiples
- Rack size (W×H×D): 483 mm × 133 mm × 280 mm (19 in × 5.2 in × 11 in)

19"-6U wall mount housing

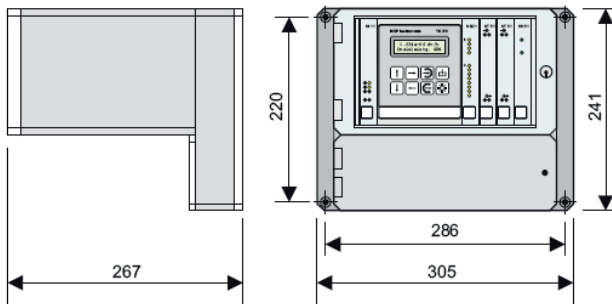

½-19" wall mount housing

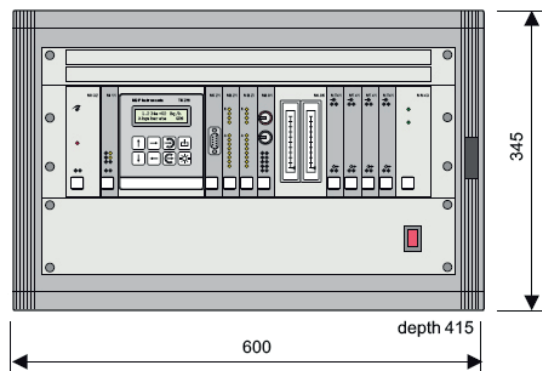

Featuring:

