



JCC-13™ / JCC-14™

Sample Inventory Coincidence Counters



KEY FEATURES

- Authorized for routine inspection use as the INVS, Inventory Sample Coincidence Counter
- Designed for passive neutron assay of plutonium
- High counting efficiency – 42%
- Variable sample cavity size
- Fast Amptek electronics
- 18 ³He detectors
- Transportable
- Optional transport container

DESCRIPTION

The JCC-13 and JCC-14 counters are based on a design developed at Los Alamos National Laboratories (LANL) in the United States under the United States Department of Energy development programs. They have also been authorized for routine inspection use of nuclear material at facilities placed under international safeguards.

The JCC-14 counter is designed to assay plutonium inventory samples inside a glovebox. It is an upgraded version of the JCC-12¹ unit, and fits around the drywell of the glovebox². Samples are loaded into an aluminum carrier inside the glovebox and then lowered into the JCC-14 counter for counting. The JCC-13 counter which is a modification of the Los Alamos National Laboratory design, differs only in the sample diameter and the method of sample loading. The JCC-13 unit is slightly larger in diameter than the JCC-14 unit, and uses top loading to minimize torn sample bags. The JCC-13 counter is a transportable counter, designed for verification inspections at multiple sites.

The JCC-13 and JCC-14 counters provide a flatter axial response and higher efficiency than the JCC-12 unit. The cylindrical-shaped sample holder accommodates various samples including liquids, powders and pellets.

The sample cavity can be enlarged by removing the polyethylene sleeve around the aluminum sample carrier.

However, enlarging the sample cavity decreases efficiency and makes the measurement more sensitive to hydrogen in the sample. The counter is intended to operate in the 0.1 to 500 g Pu mass range.

A cadmium sleeve lines the central region of the sample cavity to flatten the response profile along the length of the ³He tubes. The graphite end plugs act as reflectors. Surrounding the sample cavity is a ring of high-density polyethylene with 18 ³He proportional detectors embedded in the polyethylene.

The tubes are arranged in two concentric rings to maximize detector efficiency. The tubes are divided into three groups of six. Each group is wired together and connected to one JAB-01 Amplifier/Discriminator circuit board. The three JAB-01s are mounted inside the high voltage junction box with LED indicator lights mounted externally on the junction box to indicate proper operation of each JAB-01 channel. Electrical connections between the JCC-13 or JCC-14 counters and the JSR-12™ Neutron Coincidence Analyzer include +5 V and HV. The combination of signals will be combined into a logical OR.

The detector is portable and fits into an optional carrying case for transport.

A JSR-12 Neutron Coincidence Analyzer, a computer and analysis software are required for coincidence counting but are not included with the JCC-13 or JCC-14 counters.

SPECIFICATIONS

PERFORMANCE

- HV Setting – 1760 V.
- Gate Setting – 64 μ s.
- Die-Away Time – JCC-13: 60 μ s; JCC-14: 53 μ s.
- Detector Efficiency – 42% with smallest sample configuration.
- Sensitivity Range – 0.1 to 500 g Pu.

PHYSICAL

- Size, JCC-13/JCC-14 – 58.4 x 33.3 cm (23 x 13.1 in.) H x Dia.
- Weight, JCC-13/JCC-14 – 34 kg (75 lb).
- Sample Cavity Size
- JCC-13 – 15.75 x 6.1 cm (6.2 x 2.4 in.) H x Dia.
- JCC-14 – 15.75 x 5.2 cm (6.2 x 2.1 in.) H x Dia.
- ^3He Tubes – 18.
- ^3He Rings – 2.
- ^3He Active Length – 39.4 x 2.54 cm (15.5 x 1 in.) L x Dia.
- Cladding – Aluminum.

OPTIONS

- Transport container.
- ^{252}Cf neutron source (1 each) with source strength of 5×10^4 neutrons/sec for making routine normalization measurements. An aluminum source rod that reproduces the position of the source is included with the JCC-13 counter.
- The bottom plug can be modified to accommodate a Low Energy Germanium detector for isotopic measurements. Option must be specified at the time of purchase of the counter.

REFERENCES

1. Menlove, H.O., Holbrooks, O.R. and Ramalho, A. (1982). *Inventory Sample Coincidence Counter Manual*. Report LA-9544-M. Los Alamos, New Mexico: Los Alamos National Laboratory.
2. Miller, M.C., Menlove, H.O. and Russo, P.A. (1991). A High Efficiency Neutron Coincidence Counter for Small Samples. *Proceedings of the Fourth International Conference on Facilities Operations – Safeguards Interface*, p. 420. Albuquerque, New Mexico.

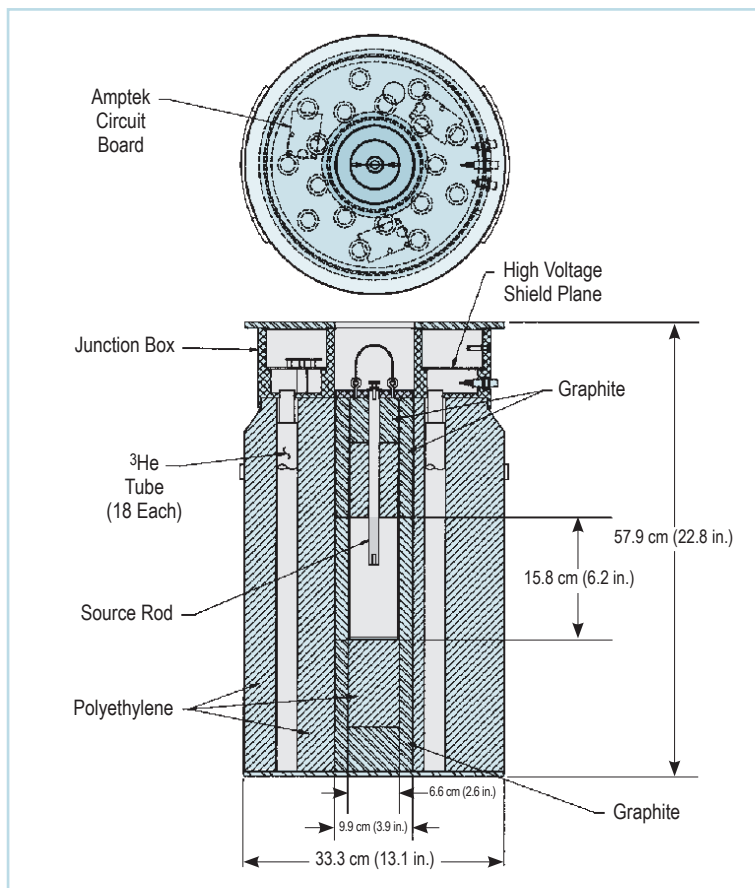

JCC-13 Sample Inventory Coincidence Counter



©2017 Mirion Technologies (Canberra), Inc. All rights reserved.

Copyright ©2017 Mirion Technologies, Inc. or its affiliates. All rights reserved. Mirion, the Mirion logo, and other trade names of Mirion products listed herein are registered trademarks or trademarks of Mirion Technologies, Inc. or its affiliates in the United States and other countries. Third party trademarks mentioned are the property of their respective owners.

CANBERRA