



SIGNAL PROCESSING

2007-2007P

Photomultiplier Tube Base/Preamplifier

The tube base connects directly to the PMT, providing one integrally mounted assembly.



FEATURES

- Mounts directly on photomultiplier tube (PMT)
- Up to + 2 kV dc PMT bias
- Separate focus and gain controls
- Model 2007 has separate anode and dynode outputs
- Model 2007P combines tube base with low noise, charge sensitive preamplifier with HV transient protection

DESCRIPTION

The Mirion Models 2007 and 2007P preamplifiers are compact PM tube bases containing a high-voltage divider network to supply all necessary bias voltages for most common 10-stage PM tubes. A focus control provides for optimization of detector resolution and a gain control permits trimming the HV bias when several tubes must be matched for array setups.

Designed for compatibility with the Mirion Model 802 Series scintillation detectors, or equivalent, the tube base connects directly to the PMT, providing one integrally mounted assembly.

The Model 2007 unit includes high-voltage blocking capacitors to couple the anode and dynode signal outputs to a preamplifier, such as the Mirion Model 2005 unit, or to a constant fraction discriminator, such as the Mirion Model 2129 unit.

The Model 2007P unit includes a preamplifier which integrates the charge impulse from the anode of the PM tube to a pulse-shaping main amplifier, such as the Mirion Model 2020 unit. The preamp features high-voltage transient protection, noise contribution less than 0.1 fC rms, and a rise time of less than 20 ns.

2007/2007P | PHOTOMULTIPLIER TUBE BASE/PREAMPLIFIER

MODEL 2007 UNIT

Inputs

- HV: Accommodates PM tube bias up to + 2 kV dc, maximum
- Detector signal: Internally ac coupled to the anode (pin 11) and last dynode (pin 10)

Outputs

- Anode: Optional 50 Ω output resistance, shunt connected; ac coupled
- Dynode: Optional 50 Ω output resistance, shunt connected; ac coupled

Controls

- Gain and focus: Screwdriver adjustable controls

Performance

- Divider bias: Total resistance 7.2 MΩ, nominal; 10 dynodes at 75 V per kV dc of detector bias
- Focus range: +72 V to +145 V per kV dc of detector bias
- Gain range: Varies total PM tube bias between 92% and 100% of applied high voltage

Connectors

- Anode and dynode: BNC
- HV: SHV
- PM tube socket: Cinch Jones 3M-14

Physical

- Size: 7.6 x 5.8 cm (3 x 2.3 in.) (L x D)
- Net weight: 0.14 kg (0.3 lb)
- Shipping weight: 1.1 kg (2.3 lb)

Environmental

- Operating temperature: 0 to 50 °C
- Operating humidity: 0 to 80% relative, non-condensing
- Meets the environmental conditions specified by EN 61010, Installation Category I, Pollution Degree 2

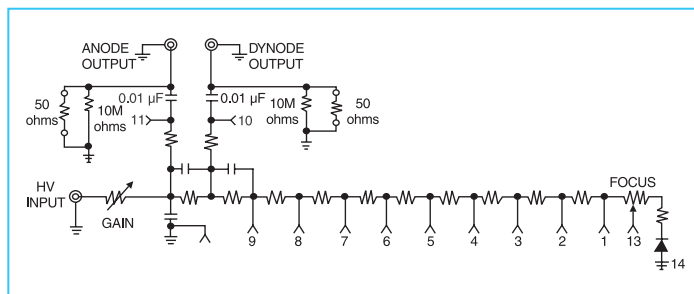

2007 Functional Schematic

MODEL 2007P UNIT

Inputs

- Detector signal: The preamp input is ac coupled internally to the anode through pin 11 of the PM tube socket
- HV: Accommodates PM tube bias up to 2 kV dc maximum
- Test: Positive or negative tail pulse from test pulse generator; charge coupled at 30 pC/V; Z_{in} = 93 Ω
- Preamp power: ±12 V dc from associated main amplifier through compatible cable provided

Outputs

- Preamp signal: Inverted tail pulse; rise time <20 ns; fall time, 50 μs nominal; up to + 10 V through series connected 93 Ω resistor; direct coupled

Controls

- Focus: Single turn screwdriver adjustment for optimization of resolution
- Gain: Single turn screwdriver adjustment for trimming HV

Performance

- Integral non-linearity: <±0.04% for up to + 10 V output
- Gain drift: <±0.01% per °C (±100 ppm/°C)
- PM tube bias isolation: + 2000 V dc maximum
- Noise: <1 fC
- Charge sensitivity: 4.5 mV/pC, nominal
- Divider bias: Total resistance 7.2 MΩ, nominal; 10 dynodes at 72 V per kV dc of detector bias; anode limiting resistor 560 kΩ
- Focus range: 72 V to +145 V per kV dc of detector bias
- Gain range: Varies total PMT bias between 92% and 100% of applied high voltage

Connectors

- Power: Amphenol 17 series
- Output and test: BNC
- HV: SHV
- PM tube socket: Cinch Jones 3M-14

Power Requirements

- Preamp: ±12 V dc at 15 mA
- HV: 0-2 kV dc at 0-300 μA

Physical

- Size: 7.6 x 5.8 cm (3 x 2.3 in.) (l x d)
- Net weight: 0.14 kg (0.3 lb)
- Shipping weight: 1.2 kg (2.7 lb)

Environmental

- Operating temperature: 0 to 50 °C
- Operating humidity: 0 to 80% relative, non-condensing
- Meets the environmental conditions specified by EN 61010, Installation Category I, Pollution Degree 2

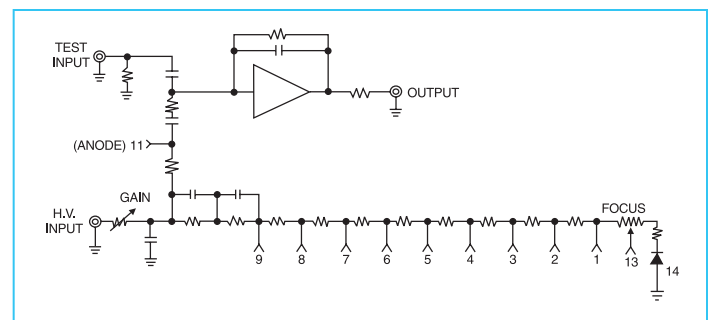

2007P Functional Schematic

