



## SIGNAL PROCESSING

# 2006

### Proportional Counter Preamplifier

This preamplifier contains a diode-protected FET input stage optimized for low noise operation.



## FEATURES

- Low noise design:  $<350$  ion pairs at  $C_s = 0$  pF
- High charge rate capacity for high count rate applications; up to  $2 \times 10^{-7}$  coulombs/second
- FET input, diode protected
- Fast risetime:  $<20$  ns at  $C_s = 0$  pF
- High voltage operation up to  $\pm 2000$  V dc



## DESCRIPTION

The Mirion Model 2006 preamplifier is designed for use with proportional counter detectors. The preamp converts the ionization charge from the detector into a step voltage pulse whose amplitude is proportional to the total charge collected in each event. The pulse decays with a time constant of  $50 \mu\text{s}$  for presentation to a main amplifier.

For typical use with a positive HV bias to the anode of the detector, the preamplifier generates positive polarity energy pulses which are shaped in the amplifier as necessary for counting or low energy x-ray analysis.

This preamplifier contains a diode-protected FET input stage optimized for low noise operation. The first stage acts as an operational integrator which produces an output potential proportional to the accumulated charge. This integrator configuration is followed by a pole/zero adjustment to return the unipolar pulse to a reference or baseline level without overshoot, and a differentiator to provide the  $50 \mu\text{s}$  tail pulse. The second active stage operates as a buffer for driving various cable lengths without pulse degradation. Conversion gains of nominally  $47$  mV/M-ion-pairs or  $235$  mV/M-ion-pairs may be selected by a jumper plug inside the unit. The higher scale factor is especially useful for best signal-to-noise ratio in experiments involving low energy sources.

The noise level is equivalent to less than 350 ion pairs with zero source capacitance using 2  $\mu$ s near-Gaussian pulse shaping, and degrades less than 1 ion pair per pF of input capacitance. As illustrated in Table 1, low noise and fast rise time prevail over a wide range of input capacitance. The high count rate capability of the design is evidenced by a charge rate capacity greater than  $2 \times 10^{-7}$  coulombs per second. In order to take full advantage of such a high count rate capability, a high count rate main shaping amplifier is recommended.

A test input is provided to assist in system setup. The test capacitor value is certified in the unit test report for reference use as a secondary charge calibration standard. The nominal voltage gain from the test output is X 1 for the output scale factor of 47 mV/M-ion-pairs and X 5 for the output scale factor of 235 mV/M-ion-pairs.

Power is supplied from the associated Mirion pulse shaping amplifier. The power lines are filtered within the unit to provide high noise immunity. A 3 m (10 ft) power cable is provided with the preamp.

Table 1

Model	C <sub>source</sub> in PicoFarads	Noise Charge Ion Pair rms Coulombs	Rise Time in Nanoseconds
2006	0	<350	<5.6 x 10 <sup>-17</sup>
	30	<380	<6.1 x 10 <sup>-17</sup>
	100	<460	<7.4 x 10 <sup>-17</sup>
	300	<660	<1.2 x 10 <sup>-16</sup>

Noise performance measured using Model 2025 Spectroscopy Amplifier set at 2  $\mu$ s unipolar near-Gaussian shaping.

**SPECIFICATIONS**

**Inputs**

- Detector input: Accepts charge pulse from a proportional counter detector, and provides HV bias to the detector
- Test input: Charge coupled to preamp input at 3.3 pC/V; Z<sub>in</sub> = 93  $\Omega$
- HV input: Allows detector bias up to  $\pm 2000$  V dc; detector series bias resistance 110 M $\Omega$

**Outputs**

- Energy output: Inverted tail pulse; rise time as in Table 1; 50  $\mu$ s fall time constant, up to  $\pm 10$  V; Z<sub>out</sub> = 93  $\Omega$ ; direct coupled

**Performance**

- Integral non-linearity: For up to  $\pm 10$  V, output unterminated: Model 2006 – < $\pm 0.02\%$
- Gain drift: < $\pm 0.01\%$  per  $^{\circ}\text{C}$  ( $\pm 100$  ppm/ $^{\circ}\text{C}$ )
- Detector bias isolation:  $\pm 5000$  V dc, maximum
- Noise output performance: See Table 1
- Charge sensitivity: 47 mV/M ion pair or 235 mV/M ion pair, internally selected
- Rise time: See Table 1

**Connectors and Cables**

- Power: Amphenol 17-20090
- Detector input: SHV
- Test input and energy output: BNC
- HV input: SHV
- Cable: One 3 m (10 ft) preamplifier power cable is supplied

**Power Requirements**

- +24 V dc – 36 mA                      +12 V dc – 2 mA
- –24 V dc – 16 mA                      –12 V dc – 2 mA

**Physical**

- Size: 7.6 x 10.2 x 4.4 cm (3 x 4 x 1.75 in.)
- Net weight: 0.34 kg (0.75 lb)
- Shipping weight: Approximately 0.5 kg (1.13 lb)

**Environmental**

- Operating temperature: 0 to 50  $^{\circ}\text{C}$
- Operating humidity: 0 to 80% relative, non-condensing
- Meets the environmental conditions specified by EN 61010, Installation Category I, Pollution Degree 2

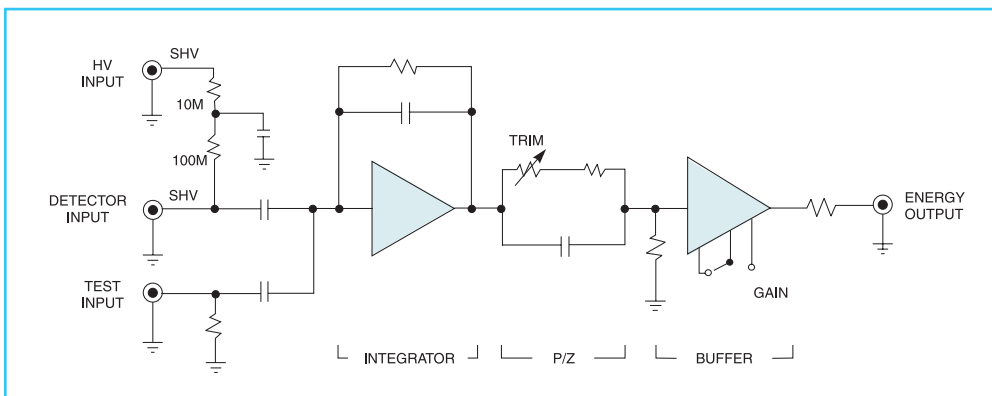

Functional Schematic

