



PROTK™ DIGITAL SIGNAL PROCESSING UNITS

DAK 260™

Digital Start-up Channel

Neutron flux monitoring during reactor start-up.

DESCRIPTION

The DAK 260 digital start-up channel forms part of the proTK™ product line.

It is used for monitoring the neutron flux during reactor start-up in the source range with a pulse-type detector or in the intermediate and power range with a gamma-compensated neutron ionization chamber (CIC). With a gamma radiation detector, it can also be used in safety critical radiation or process monitoring applications.

Hardware and software of the DAK 260 channel is designed and qualified for use at the level of the reactor protection system.

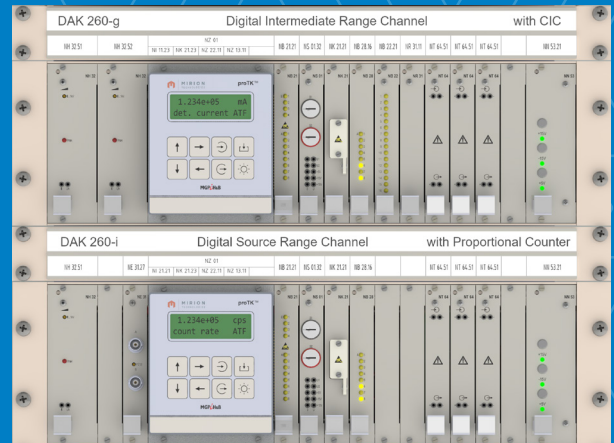

FEATURES

- ✓ Modular design, highly customizable
- ✓ For proportional and fission counters or γ -compensated ionization chambers
- ✓ Provides the count rate, calibrated n-flux (nv) or reactor power (%FP, W, ...)
- ✓ Calculation of flux change rate (reciprocal of the reactor period)
- ✓ Signal filtering with adaptive filter parameters
- ✓ Generation of analog output signals with lin. or log. scaling (optional: linear multi-range signal incl. range indication)
- ✓ Generation of binary alarm, trip and status indication signals
- ✓ Remote activation of integrated test signal generators
- ✓ Secured serial interface
- ✓ Qualified for Category A functions (Class 1 systems) acc. IEC 61226

DAK 260™ START-UP NEUTRON FLUX MONITORING CHANNEL

DIGITAL SIGNAL PROCESSING	
Multi-processor system	
Protected program memory	
Non-volatile parameter memory	
RS-232 and/or RS-485 serial interface for: measurement data, status information and parameter setting	
Internal LC-display: 2 x 16 characters	

OUTPUT SIGNALS	
Log. count rate, neutron flux or reactor power	0.5 ... 5e+5 cps 1E+2 ... 1e+10 nv 1.5E-6 ... 1.5e+2 %FP
Linear count rate (DAK 260-i) Linear power (DAK 260-g)	0 ... 1E+5 cps 0 ... 150 %FP
Relative flux change rate (log rate = 1 / reactor period)	-1.25 ... 0 ... +12.5 %PP/s (equiv. period -80 ... ∞ ... +8 s)
Linear multi-range power signal with range indication	full scale: 125/40/12.5/ ... %FP (16 ranges / half-decades)
Analog outputs	0/4 ... 20 mA / 600 Ω, isolated
Binary outputs (isolated relay changeovers)	60 V / 0.5 A or 125 V / 1 A

The shown scaling of the output signals are examples and can be configured according to the application requirements.

PRE-AMPLIFIERS	
Pulse pre-amplifier NV 320	Characteristic I/O impedance matched to cables (e.g. 50 or 75 Ω)
I/F converter (for ion. chambers) NV 102 NV 103	10 decades of meas. range: 1e-13 A ... 1e-3 A 1e-14 A ... 1e-4 A
Integrated test signal generators (pulses, AC and DC)	Activation via HMI or through serial interface.

DETECTORS	
Pulse detectors for DAK 260-i	BF3 or He-3 counter tubes B-10 proportional counters Fission counters
Ionization chambers for DAK 260-g	Gamma compensated or un-compensated neutron ionization chambers (e.g. KNK/KNU 50 ACH)
High voltage supply from HV module(s) in DAK 260	Adjustable within max. range: 0 ... 0.5/1/2/4 kV

OTHER CHARACTERISTICS	
AC / DC power supply 230 VAC or 115 VAC 18 ... 33 VDC	+10% / -15%, approx. 30 VA
Operating temperature open rack recommended long-term op.	0 ... 70 °C / 32 ... 158 °F 10 ... 40 °C / 50 ... 104 °F
Mechanical vibrations	max. 5 g, 5 ... 100 Hz (or acc. custom requirements)
Dimensions (mm / inch) Rack (W×H×D) Plug-in modules	19" system acc. IEC 60297 483 × 133 × 280 / 19 x 5.2 x 11 100 × 160 / 3.9 x 6.3

QUALIFICATION / DESIGN STANDARDS (SELECTION)	
Design	IEC 61513 / IEEE 603
Software	IEC 60880 / IEEE 7.4.3.2
Qualification	IEC/IEEE 60780-323 IEC/IEEE 60980-344

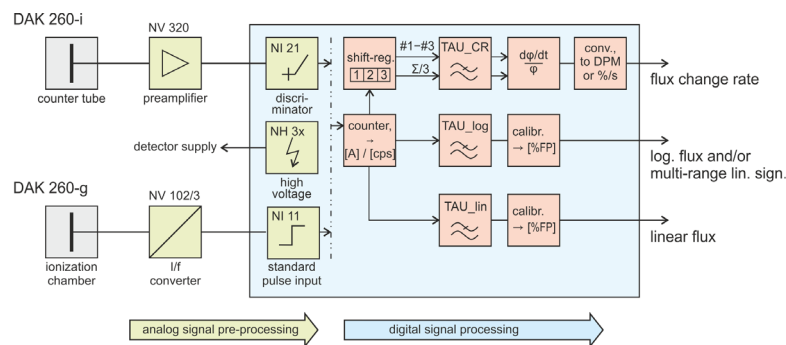

Copyright © 2023 Mirion Technologies, Inc. or its affiliates. All rights reserved. Mirion, the Mirion logo, and other trade names of Mirion products listed herein are registered trademarks or trademarks of Mirion Technologies, Inc. or its affiliates in the United States and other countries. Third party trademarks mentioned are the property of their respective owners.