



DETECTORS

# Intelligent Cryo-Cycle™

## Hybrid Cryostat



The Mirion Intelligent Cryo-Cycle Cryostat is the latest enhancement of the “hybrid” cryostat combining the advantages of electric cooling with the reliability of liquid nitrogen. The cryocooler is used to condense the boil-off  $N_2$  gas back into the 25-liter Dewar. This unique capability provides the convenience of operating a detector for up to two years before  $LN_2$  needs to be added, but at the same time keeps the detector cold in case of power failure.

With the Intelligent Cryo-Cycle Cryostat, the  $LN_2$  supply keeps the detector cold for up to seven days without power. There is no interruption of cooling and, as a result, there is no down time due to partial warm up as long as  $LN_2$  is maintained. In addition, there is no risk of detector failure because of temperature cycling.  $LN_2$  lost during power outages may be replenished at any time.

### FEATURES

- ✓ Low-vibration/low electrical noise even at low energies (no spectral resolution degradation)
- ✓ Low audible noise (<50 dB(A) at 1 m)
- ✓  $LN_2$  redundancy
- ✓ Non-CFC/non-flammable refrigerant
- ✓ Same footprint as standard  $LN_2$  Dewar
- ✓ Low power demand (130 W nominal for typical detector configuration)
- ✓ Local and remote State-of-Health (SoH) monitoring
- ✓ Four years of onboard system memory for State-of-Health storage
- ✓ Available in dipstick and integral configurations
- ✓ No maintenance required
- ✓ Low operating cost
- ✓ Designed for maximized detector uptime
- ✓ Field installable (dipstick version)
- ✓ Extremely quiet (<50 dB(A) at 1 m)
- ✓ No compromise on detector specifications

## INTELLIGENT CRYO-CYCLE HYBRID CRYOSTAT

The Intelligent Cryo-Cycle Cryostat is designed for optimal reliability and serviceability. Mirion prioritizes cooler functionality, as it determines overall reliability of the complete unit. The Mirion Cryo-Pulse® 5 Plus cooler has a proven track record since 2006, and Mirion has developed the new cooler with the same supplier. Beyond State-of-Health (SoH) parameters already tracked in previous Cryo-Cycle versions the Intelligent Cryo-Cycle Cryostat monitors even more parameters with automatic logging into the memory for optimal performance and efficient servicing.

The critical hardware parameters are directly displayed on the integrated LCD display on the front panel:

- LN<sub>2</sub> level enabling better scheduling of periodic refill;
- N<sub>2</sub> gas pressure, cooler power, heater status, internal air temperature and cooler compressor temperature as monitor for the state of health.

In case of a warning or alarm condition, the LCD screen will respectively light up yellow or red and the corresponding warning/alarm message is displayed on the screen. This will help the user in making a prompt and correct diagnosis.

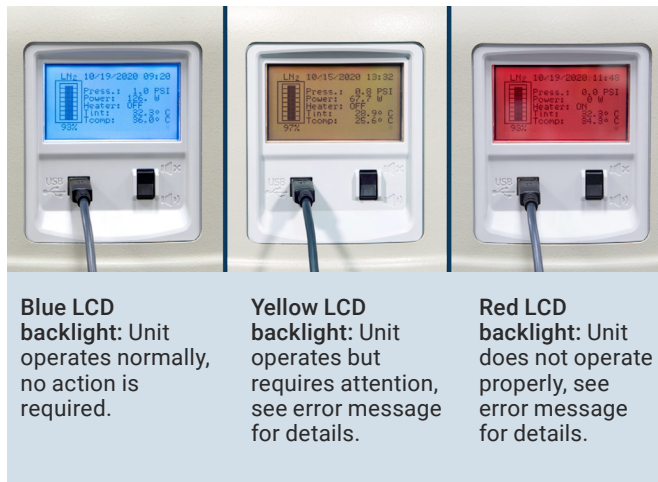

A USB connector is provided below the integrated LCD display for establishing a connection to a local PC/laptop on a desk or tablet in front of the lead shield for monitoring the SoH data with the Intelligent Cryo-Cycle Display Application. Operating system requirements for the application are Windows 7 (64-bit), Windows 8.1 (64-bit) or Windows 10 (64-bit). The Intelligent Cryo-Cycle Display Application is also used to:

- Set date and time according to the correct time zone;
- Set a customized name;
- Download the internally stored log file. Thanks to the onboard memory, the user always has access to a complete log file of all hardware parameters even though the device was not connected to a PC.

The audible noise has been considerably reduced to less than 50 dB(A) below 35 °C (95 °F), measured at 1 m distance, making the Intelligent Cryo-Cycle Cryostat well suited for use in quiet laboratory environments.

The Intelligent Cryo-Cycle cryostat accommodates both dipstick and integral configurations. Dipstick versions can be installed in the field, while integral versions must be assembled at the factory. Any vibrations originating from the cryocooler are controlled to such a level that, when the Intelligent Cryo-Cycle unit is sold with a new Mirion detector, there will be no degradation of the detector's resolution performance as stated on the detector's specification sheet. For older Mirion detectors or detectors not manufactured by Mirion, resolution performance cannot be guaranteed in general. Please consult the factory for technical options to optimize the performance of your existing detector.

The Intelligent Cryo-Cycle Cryostat is provided with a highly reliable and efficient cryocooler. The cooler is hermetically sealed containing a CFC-free and non-flammable gas, which does not require gas refills. The compressor does not contain oils or lubricants which eliminates contamination of the refrigerant. This means that you do not need to perform any maintenance. The total nominal power consumption is very low (130 W for a typical configuration), with a maximum of 285 W in transient operation. The Intelligent Cryo-Cycle Cryostat is designed to operate between 5 °C and 35 °C.

Mirion's confidence in the Intelligent Cryo-Cycle product is demonstrated by the two-year warranty on the complete system, except for the collar part.

## INTELLIGENT CRYO-CYCLE HYBRID CRYOSTAT

### SPECIFICATIONS

#### Performance:

- Mirion guarantees detector performance as warranted by detector model with cooler in operation (on new detectors purchased with the Intelligent Cryo-Cycle Cryostat)
- LN<sub>2</sub> loss rate <4 liters/day typically (with cryostat installed and cryocooler OFF)
- LN<sub>2</sub> level and SoH monitoring: LCD screen on front panel

#### Connectors:

- USB 2.0: Remote status read-out

#### Cooling:

- Forced air (internal fans)

#### Power Requirements:

- 100–240 V ac, 50–60 Hz, 140 VA typical, 300 VA Max. (auto-ranging power supply)
- Fuse: 100-240 V (2) T 10A H 250 V

### PHYSICAL

#### Cold Head (Excluding detector chamber):

- Dimensions: 43.2 cm (17 in.) diameter x 61.0 cm (24 in.) high
- Weight: 30 kg (66 lb) empty without detector chamber
- Dewar-capacity: 25 liters

#### Environmental:

- Operating temperature: +5 to +35 °C (41 to 95 °F) on standard models and configurations
- Operating humidity:
  - Range: 20% to 80% relative non-condensing

#### Software:

- System Requirements: Windows 7 (64-bit), Windows 8.1 (64-bit), Windows 10 (64-bit)

#### Available Detector Models:

- Intelligent Cryo-Cycle Cryostats can be ordered with all standard GC-, GX-, GR-, BE-, and GSW-detector models (see applicable detector specification sheets for details)

### ORDERING INFORMATION

- iCC-VD Intelligent Cryo-Cycle for vertical dipstick models
- iCC-HD Intelligent Cryo-Cycle for horizontal dipstick models
- iCC-VI vertical integral Intelligent Cryo-Cycle
- iCC-HI horizontal integral Intelligent Cryo-Cycle

## INTELLIGENT CRYO-CYCLE HYBRID CRYOSTAT

## INTELLIGENT CRYO-CYCLE WITH VERTICAL DIPSTICK CRYOSTAT (ICC-VD)

## INTELLIGENT CRYO-CYCLE WITH 7500SL-RDC CRYOSTAT

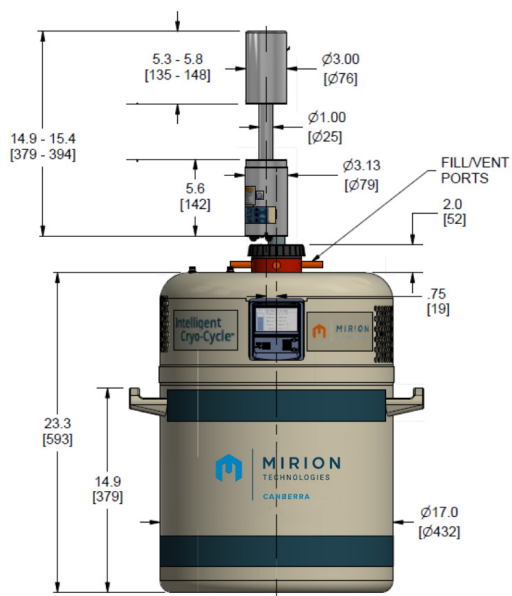

Side View

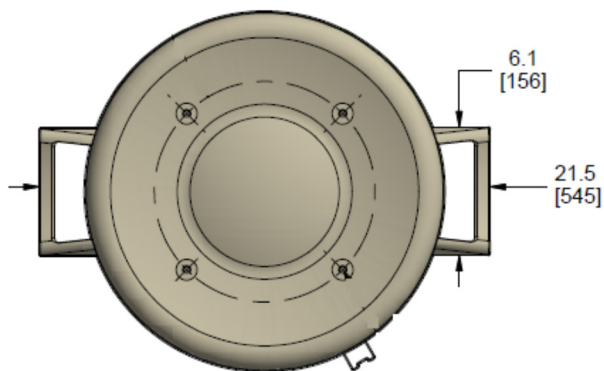

Bottom View

End cap dimensions depend on detector size. The tables below show the typical surface area or efficiency range vs. end cap diameter. End cap lengths are also greater for larger detectors. Consult the factory if end cap size is critical in your application.

LEGe/BEGe, Nom. Area (mm <sup>2</sup> )	End Cap Diameter, mm [in.]	Coax Rel. Efficiency (%)	End Cap Diameter, mm [in.]
=<2000	76 [3.0]	=<40	76 [3.0]
2800	83 [3.25]	40-50	83 [3.25]
3800	89 [3.50]	50-70	89 [3.50]
5000	102 [4.0]	70-100	95 [3.75]
6500	114 [4.50]	100-120	102 [4.0]
		120-150	108 [4.25]
		150	114 [4.50]

## INTELLIGENT CRYO-CYCLE HYBRID CRYOSTAT

## INTELLIGENT CRYO-CYCLE WITH HORIZONTAL DIPSTICK CRYOSTAT (ICC-HD)

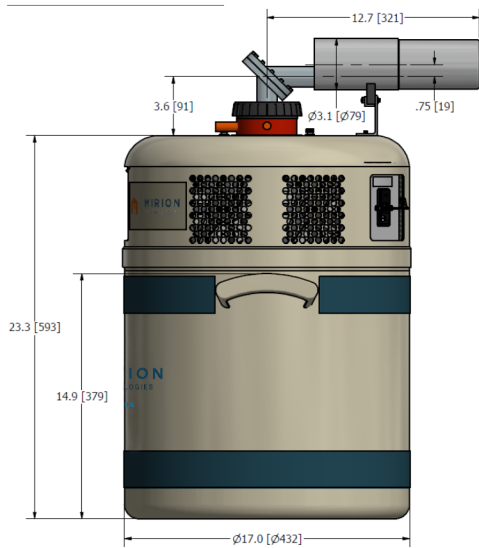

Side View

## INTELLIGENT CRYO-CYCLE WITH 7600SL CRYOSTAT

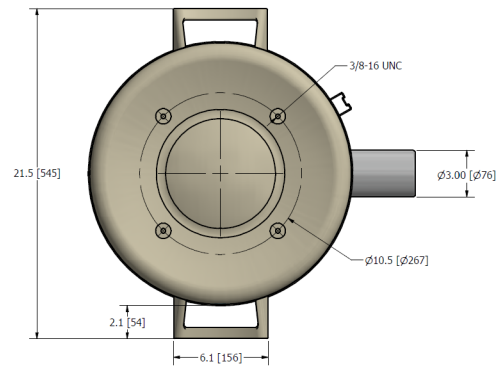

Bottom View

## INTELLIGENT CRYO-CYCLE WITH HORIZONTAL INTEGRAL CRYOSTATS (ICC-HI)

## INTELLIGENT CRYO-CYCLE HORIZONTAL INTEGRAL U-STYLE™ CRYOSTAT

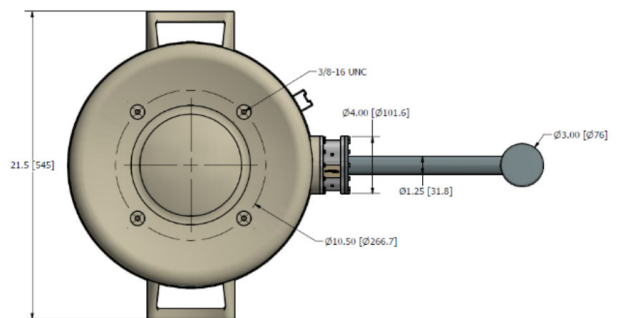
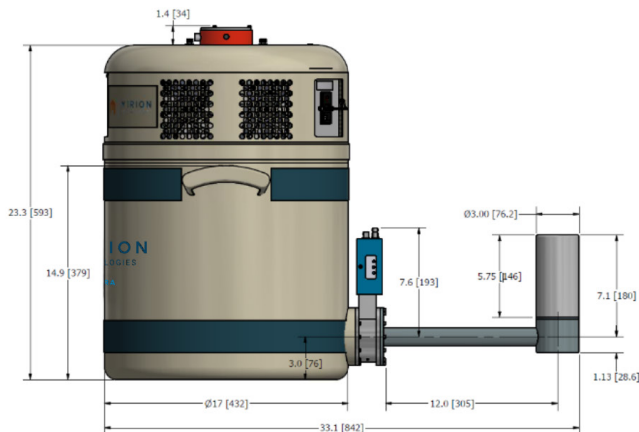

**INTELLIGENT CRYO-CYCLE HYBRID CRYOSTAT**

**INTELLIGENT CRYO-CYCLE WITH HORIZONTAL INTEGRAL CRYOSTATS (ICC-HI) CONTINUED**

**INTELLIGENT CRYO-CYCLE HORIZONTAL INTEGRAL FLANGED™ STYLE**

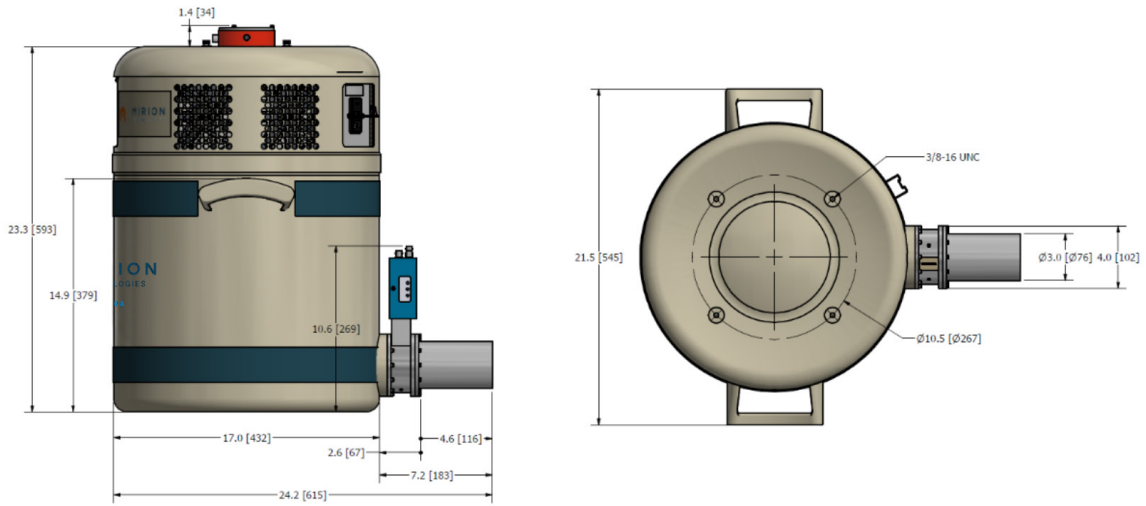

**INTELLIGENT CRYO-CYCLE HORIZONTAL INTEGRAL FLANGE RDC STYLE**

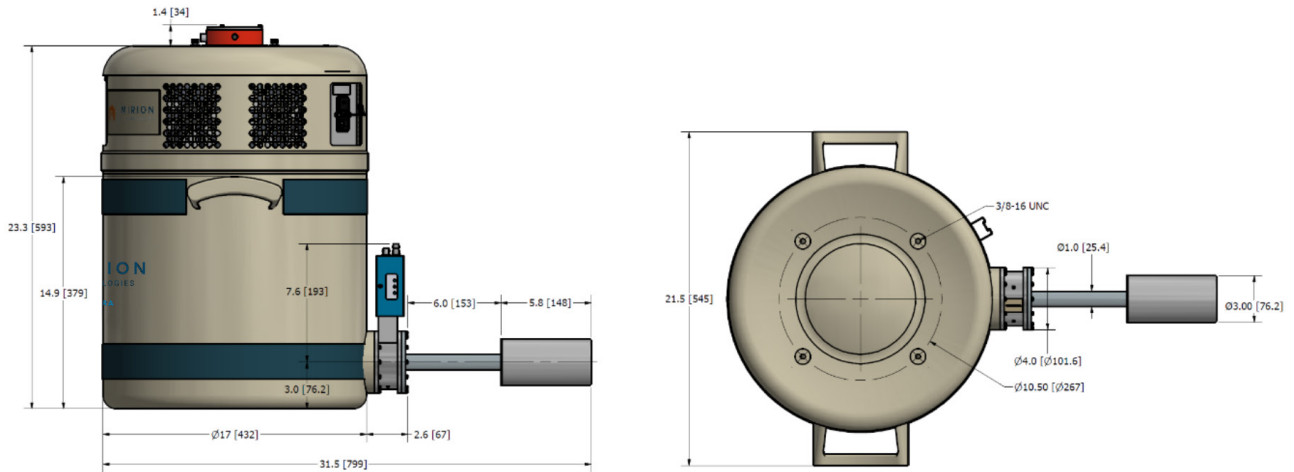

**INTELLIGENT CRYO-CYCLE HORIZONTAL INTEGRAL SLIMLINE™ STYLE**

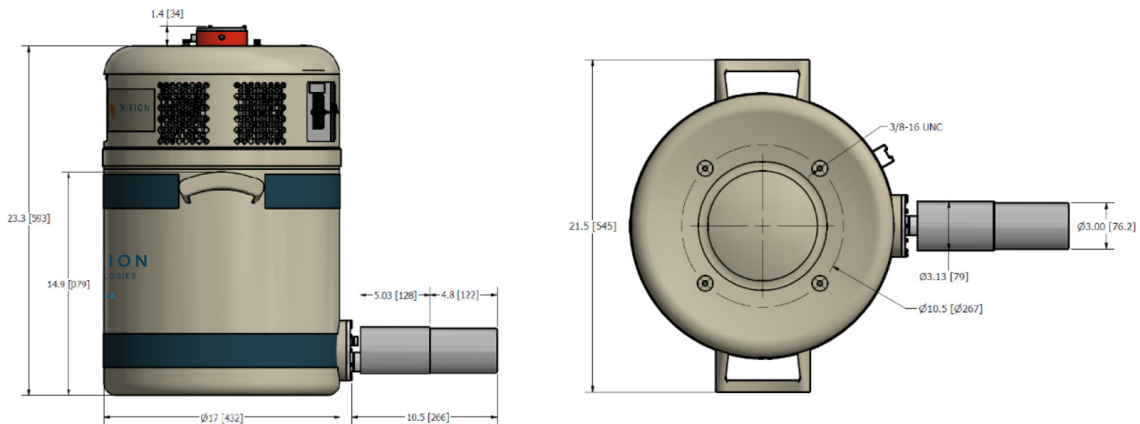

**INTELLIGENT CRYO-CYCLE HYBRID CRYOSTAT**

**INTELLIGENT CRYO-CYCLE WITH VERTICAL INTEGRAL CRYOSTATS (ICC-VI)**

**INTELLIGENT CRYO-CYCLE VERTICAL INTEGRAL FLANGED STYLE**

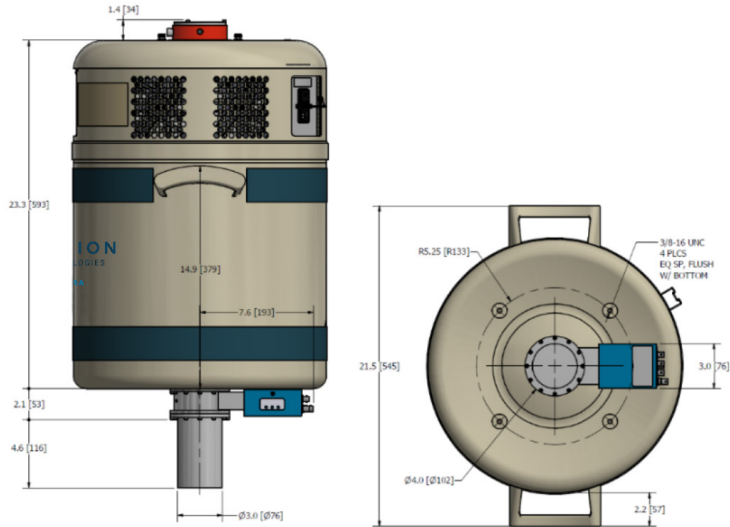

**INTELLIGENT CRYO-CYCLE VERTICAL INTEGRAL SLIMLINE STYLE**

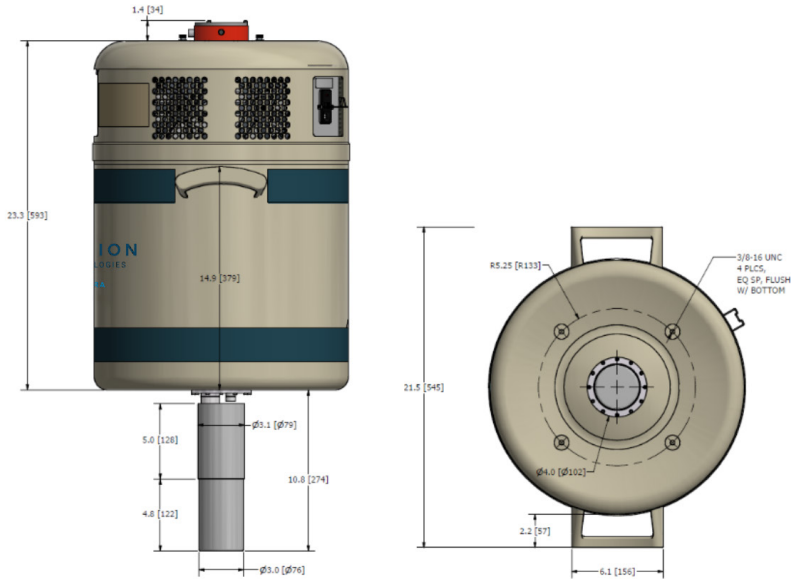

Copyright © 2025 Mirion Technologies, Inc. or its affiliates. All rights reserved. Mirion, the Mirion logo, and other trade names of Mirion products listed herein are registered trademarks or trademarks of Mirion Technologies, Inc. or its affiliates in the United States and other countries. Third party trademarks mentioned are the property of their respective owners.