



# RoboCount™ 2020

## Robotic Gamma Waste Assay System



Extensive operational experience from previous models has been taken into account in the design of the RoboCount 2020, overcoming the shortcomings of traditional gamma scanners.

The key idea in designing RoboCount 2020 was to use a proven industrial robotic platform, combine it with the best available high-resolution gamma spectrometry hardware and software, and provide seamless control by a dedicated multiplatform user application.

### ROBOT

The core of RoboCount 2020 is a 6-axis industrial robot – COMAU Smart 5 NJ 220 2.7 Safe with a useful load of up to 220 kg. The robot is significantly over-dimensioned to virtually eliminate wear and to allow for future use of multiple detectors and/or more massive lead shielding.

A separate waste package rotator (7th robot axis) increases the flexibility of the system by allowing traditional segmented scanning (SGS) as well as measurements of homogeneous waste packages by integral gamma scanning (IGS).

### FEATURES

- ✓ Robotic gamma waste assay system
- ✓ Non-destructive assay of 100 L, 200 L, 400 L radioactive waste packages, crates, pallets, FIBSs, etc.
- ✓ Wide range of high-purity germanium detectors, liquid nitrogen (LN<sub>2</sub>) or electrical detector cooled
- ✓ Multichannel analyzer (MCA) with digital signal processing (DSP)
- ✓ Selection of custom collimators for any waste package size, activity, and assay type
- ✓ Separate waste package rotator with integrated scale
- ✓ Heavy-duty, low-maintenance design based on an industrial robot platform
- ✓ Powder-coated finish for ease of cleaning and decontamination
- ✓ Operated by tightly integrated RoboCount 2020 waste assay software
- ✓ Options including bar code reader, dose rate sensor(s), spray paint labeling, etc.

## ROBOCOUNT 2020 ROBOTIC GAMMA WASTE ASSAY SYSTEM

### INTRODUCTION

Non-destructive assay (NDA) is an important part of any radioactive waste management operation, from nuclear power plants to institutional users of radioactive material. As radioactive waste is typically stored in waste packages, standardized solutions for NDA of specific types of waste packages have been developed in the form of 'gamma scanners'. Traditional gamma scanners are frequently compatible with just one waste package type, e.g., the 200 L drum, and perform just one measurement type, e.g., segmented gamma scanning.

However, situations where several types of waste packages need to be assayed, a wide range of activities and/or dose rates is to be covered, more than one assay type is desired, etc. are becoming increasingly common. Instead of acquiring several dedicated units, it seems preferable to employ a universal NDA system capable of assaying any waste package in an unrestricted choice of geometries, following any current or future measurement protocol. Meet the robotic gamma waste assay system RoboCount 2020!

The robust waste package rotator is capable of handling waste packages of up to 2500 kg. It features adjustable brackets for waste packages of varying diameters, rotation speeds adjustable from 1 to 10 rpm with soft start/stop, and an integrated waste package scale with a resolution of + 1 kg.

RoboCount 2020 is fully computer controlled from the system PC through a COMAU C5G industrial robot controller with a teach pendant. A number of system functions are also accessible via a touch screen panel on the teach pendant.

### DETECTOR & CRYOSTAT

A wide variety of high-purity germanium HPGe detector types are supported by RoboCount 2020, including standard coaxial detectors as well as broad energy detectors. The detector of choice is mounted in a remote detector chamber cryostat. This allows a backshield to be used, minimizing any interfering radiation that may enter the rear of the detector. Whichever type and size of detector is chosen, its energy response can be determined by mathematical or empirical calibration.

RoboCount 2020 is designed to accommodate a multi-attitude liquid nitrogen (LN<sub>2</sub>) cryostat with a LN<sub>2</sub> capacity of 7 L and a holding time of up to about five days. LN<sub>2</sub> refill from a 50 L or larger supply Dewar is fully automated. At predetermined intervals, the robot connects the detector Dewar to a docking station and a refill is initiated. It stops when the temperature sensor in the outlet port detects the change from gaseous to liquid nitrogen. The robot then undocks the detector.

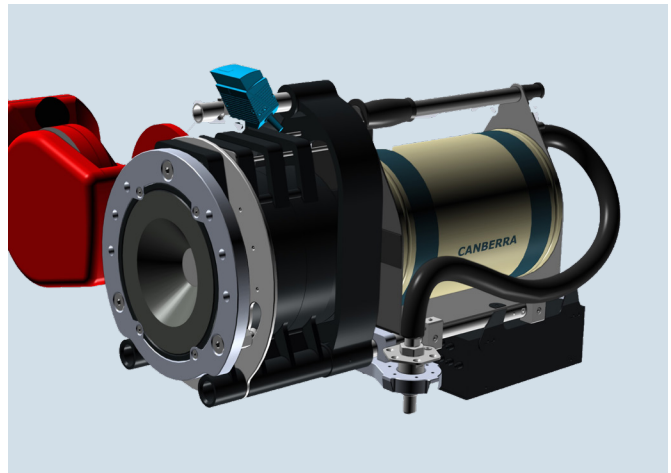

If a central building LN<sub>2</sub> supply is available, even the supply Dewar exchanges could be eliminated. For ultimate convenience, an electrical cryostat is available as an option.

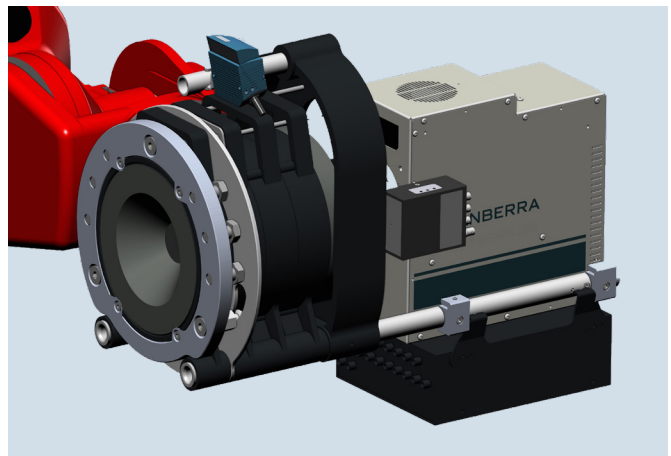

## ROBOCOUNT 2020 ROBOTIC GAMMA WASTE ASSAY SYSTEM

### COLLIMATOR

RoboCount 2020 features a unique collimator consisting of three fixed cylindrical shielding elements and an exchangeable collimator segment which is automatically selected by the software based on the waste package and assay type, detector dead time, waste package dose rate, etc. The selected collimator segment is picked up by the robot from a collimator tray and attached to the front of the detector shield assembly.

A set of custom collimators is supplied with each RoboCount 2020, their number and type determined by package type/size, activity, and assay type. They might include a collimator with a rectangular aperture (horizontal slit) optimized for SGS of drums, conical aperture for IGS of large waste packages, etc. Collimator selection is made by the control software based on the measured detector dead time or measured waste package dose rate, waste package type, and assay type. In addition to the robotic collimator change, the distance between the detector and the waste package is also automatically adjusted to provide an optimal detector field of view.

### MCA

The selection of a multichannel analyzer (MCA) is guided by the necessary compatibility with the HPGe detector, performance specifications, mechanical robustness, physical size, and the available communication interface. An MCA with digital signal processing (DSP), capable of being mounted as close as possible to the detector for minimum interference, is recommended. Undisturbed communication with the remote-control PC requires a LAN connection.

### SOFTWARE

The RoboCount 2020 is operated by dedicated software designed to be a complete acquisition, analysis and archival package for use specifically and exclusively with RoboCount 2020. The software is seamlessly integrated with the award-winning Canberra™ Genie software, providing the ease and flexibility of operation found in the popular gamma-ray spectroscopy applications.

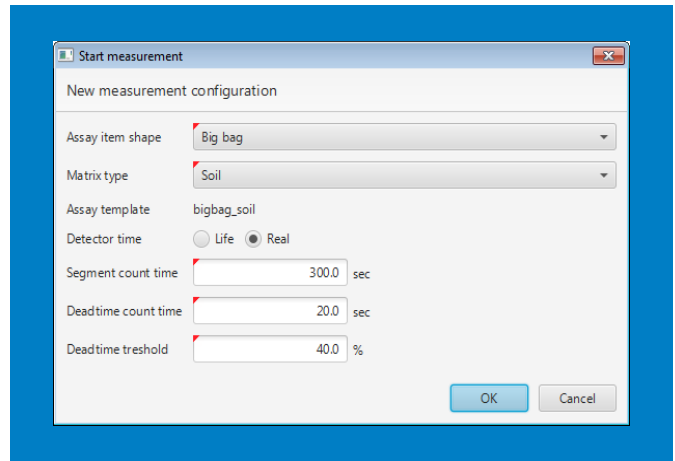

Following setup, operation can be as simple as a single click of the mouse where a full assay sequence is launched requiring little or no operator intervention. The software supports a variety of analysis types to provide flexibility in sample assay. With the Genie Analysis Sequence Editor it is possible to select which type or types of analysis is to be performed for a given sample. Various counter arrangements, detector arrangements, analysis sequences, hardware control, and reports can be generated from the standard software.

A variety of standard reports have been created. However, a special feature of Genie and RoboCount 2020 software is the capability for the customer to edit existing or create new report templates which will fit particular site requirements. All report structures can be easily edited in a standard ASCII editor. Any parameter which is stored in the CAM file can be included in a report.

Analysis is performed automatically during and following completion of the assay. The data may also be completely reanalyzed using the Data Review menus. Data storage utilizes the Genie CAM file format. Data files may be reanalyzed one at a time or if many assay results require the same parameter correction, a batch reanalysis capability is provided.

# ROBOCOUNT 2020 ROBOTIC GAMMA WASTE ASSAY SYSTEM

## PERFORMANCE

Actual measurement performance depends on detector size, assay time, measurement geometry, etc. Measurement geometries for crates (90° cylindrical collimator, 30 cm detector – WP distance; (30° cylindrical collimator, 120 cm detector – WP distance) and FIBCs (90° collimator, 40 cm detector – WP distance; (30° collimator, 160 cm detector – WP distance), respectively, are depicted below.

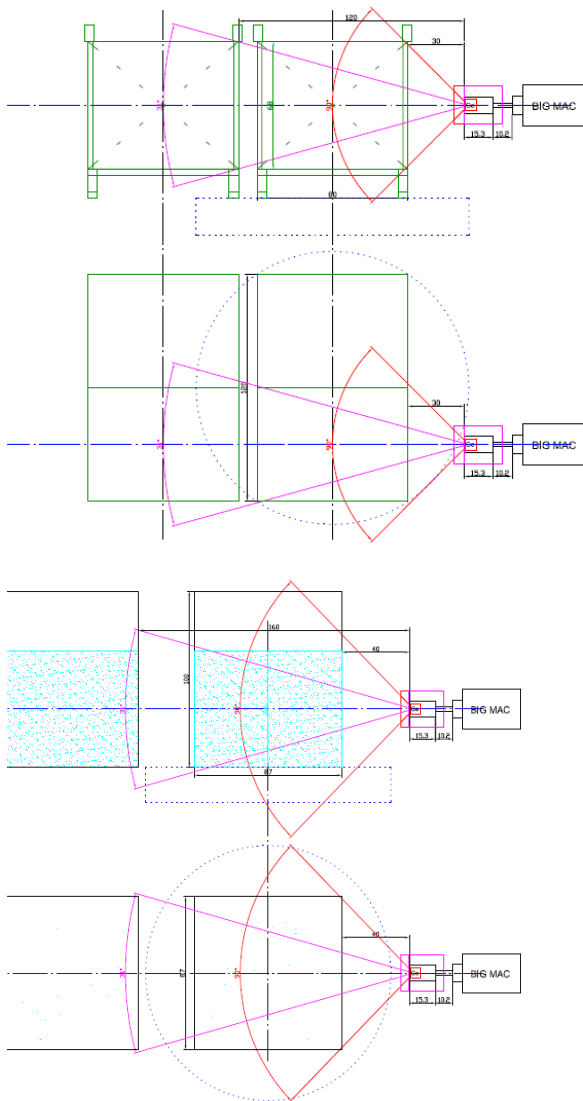

Typical results evaluated for steel scrap (1.5 g/cm<sup>3</sup>) in crates and concrete rubble (2.0 g/cm<sup>3</sup>) in FIBCs, respectively, are shown below.

Waste Package	Crate, 1200 x 800 x 800 mm		
Matrix Material	Steel Scrap		
Matrix Density / kg.m <sup>-3</sup>	1.5		
Geometry	90°, 30 cm		
Nuclide	<sup>137</sup> Cs	<sup>60</sup> Co	
Energy / keV	661.6	1173.2	1332.5
Peak Efficiency	4.51E-6	3.79E-6	3.66E-6
Count Rate @ 10 <sup>5</sup> Bq / cps	0.4	0.4	0.4
Counts @ 10 <sup>5</sup> Bq in 240 s	92	91	88
Count Rate @ 10 <sup>9</sup> Bq / cps	3842	3790	3660
Counts @ 10 <sup>9</sup> Bq in 240 s	922 205	909 600	878 400

Geometry	30°, 120 cm		
Nuclide	<sup>137</sup> Cs	<sup>60</sup> Co	
Energy / keV	661.6	1173.2	1332.5
Peak Efficiency	1.77E-7	2.09E-7	2.18E-7
Count Rate @ 10 <sup>5</sup> Bq / cps	151	209	218
Counts @ 10 <sup>5</sup> Bq in 120 s	18 120	25 080	26 160

Waste Package	FIBC, 870 x 870 x 1000 mm		
Matrix Material	Concrete Rubble		
Matrix Density / kg.m <sup>-3</sup>	2.0		
Geometry	90°, 40 cm		
Nuclide	<sup>137</sup> Cs	<sup>60</sup> Co	
Energy / keV	661.6	1173.2	1332.5
Peak Efficiency	4.20E-6	3.45E-6	3.32E-6
Count Rate @ 10 <sup>5</sup> Bq / cps	0.4	0.3	0.3
Counts @ 10 <sup>5</sup> Bq in 240 s	86	83	80
Count Rate @ 10 <sup>9</sup> Bq / cps	3578	3450	3320
Counts @ 10 <sup>9</sup> Bq in 240 s	858 816	828 000	796 800

Geometry	30°, 160 cm		
Nuclide	<sup>137</sup> Cs	<sup>60</sup> Co	
Energy / keV	661.6	1173.2	1332.5
Peak Efficiency	1.15E-7	1.31E-7	1.35E-7
Count Rate @ 10 <sup>5</sup> Bq / cps	98	131	135
Counts @ 10 <sup>5</sup> Bq in 120 s	11 760	15 720	16 200

The accuracy of the measurement is based on the assumed uniformity of the activity as well as matrix density distribution within the waste package. Typical accuracies are ±20% for waste packages with matrix densities up to 1 g/cm<sup>3</sup>.

## SAFETY

RoboCount 2020 is compliant with all applicable safety regulations, in particular 2006/42/EC and equipped with software and hardware motion range limiting devices.

For added personnel protection, the entire robot work area is surrounded by a light curtain. Interruption of any light beam will result in an immediate cessation of all mechanical motions of the robot. In situations where the safety perimeter around the robot is not rectangular, a safety scanner can replace or complement the light curtain.

# ROBOCOUNT 2020 ROBOTIC GAMMA WASTE ASSAY SYSTEM

## SPECIFICATIONS

- Waste package weight up to 2500 kg
- Waste package diameter up to 1500 mm
- Detector positioning around 6 axes
- Liquid nitrogen HPGe detector cooling, automatic refill from 50-200 L supply Dewar
- Set of custom collimators, robotic change
- Waste package rotation speed range 1 - 10 rpm with soft start/stop
- Integrated waste package scale, precision + 1.0 kg
- Weights (nominal)  
Robot 2500 kg  
Rotator module 475 kg  
Control cabinet 305 kg
- Dimensions of work area 5500 x 5500 x 3200 mm (L x W x H)
- Power requirements 3L+N+PEAC 400 V, 50 Hz, 18 A, 12/30 kVA
- Environmental conditions 0 – 50 °C, max. 80% rel. humidity

## OPTIONS & ACCESSORIES

- Electrical HPGe detector cooling
- Dose rate sensor(s) for pseudo-contact, 1 m, or other measurements, maximum and average value determination, dose rate mapping
- Bar code reader, 1D laser-based or 2D/QR camera-based, fixed location or find/read
- Unattended QA measurements – check source measured without collimator, periodically or as needed
- One or two additional HPGe detectors and a field-of-view lead shielding for low-MDA clearance measurements
- Attachment for taking smear samples of waste package surfaces
- Attachment for industrial spray marking of waste packages
- Transmission source robotic module, sealed radioactive source in a lead shield, enabling matrix density correction and/or transmission tomography
- Automatic assay of more than one waste package in a batch – infeed/outfeed conveyors or integration with a robotic pallet truck or fork lift

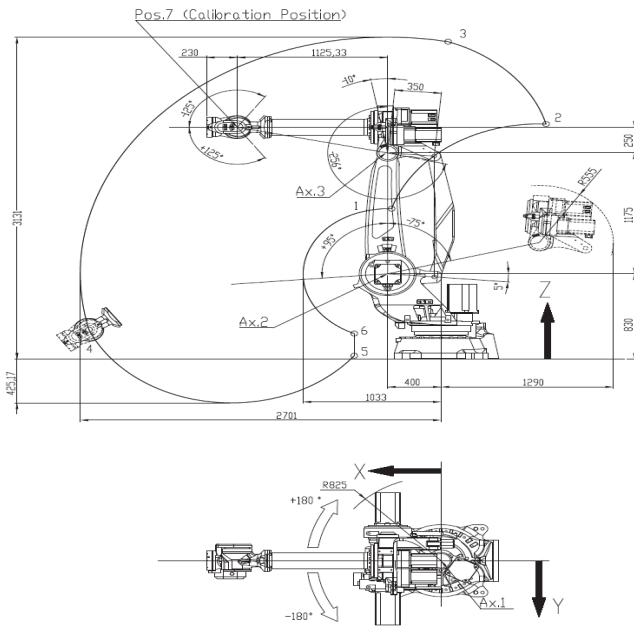

Copyright ©2024 Mirion Technologies, Inc. or its affiliates. All rights reserved. Mirion, the Mirion logo, and other trade names of Mirion products listed herein are registered trademarks or trademarks of Mirion Technologies, Inc. or its affiliates in the United States and other countries. Third party trademarks mentioned are the property of their respective owners.

Specifications may vary according to system configuration. We reserve the right to modify or amend the information herein without prior warning. Please contact your Mirion representative for further information.

Mirion Technologies (IST) Ltd and Mirion Technologies (Imaging), LLC are ISO 9001:2015 certified companies (certificates available on request or at [www.mirion.com](http://www.mirion.com)).

Please note that the products and accessories described in this data sheet may be subject to UK export control or US re-export control. Please check with your authorized representative when enquiring about this product.